

THE
ORGANIC
COMPANY



2026

VOL. 1

LOOK BOOK



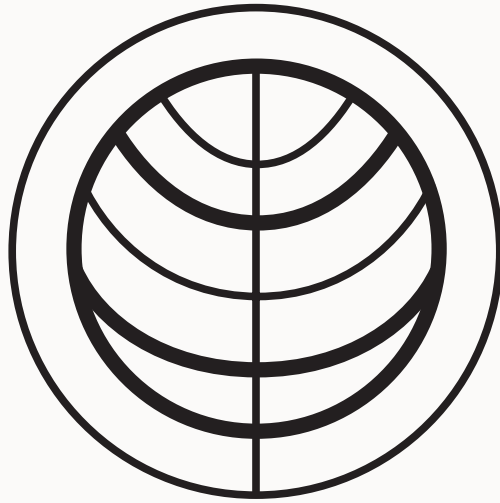

TOGETHER FOR CHANGE



WHY WE ARE HERE

At The Organic Company, we work for a better future.

Our approach is based on creating less, but better: thoughtful products that meet real needs rather than trends. We want our products to last as long as possible, so that they can be passed on. Therefore we develop products that can be used again and again.

We believe in organic principles and are on a journey toward regenerative and circular solutions, which are advancing steps from being B CORP and GOTS certified. Something good, trustworthy and solid to advance from.

We take responsibility for both people and nature, and we see it as our duty to raise awareness and act – always guided by care, transparency, and long-term thinking.

We envision a world where all companies, regardless of size, take social, environmental and financial responsibility throughout the entire value chain.

We believe in the human ability to change and we believe in the future.

That's why we are here.

Sincerely,

The Organic Company

ABOUT US

- 003** Our purpose
- 007** Our story
- 008** Regenerative
- 112** We are B Corp certified
- 113** GOTS certification
- 114** Find us

LOOK AND FEEL

- 012** Colours
- 014** Seasonal colours
- 034** Functional design
- 108** POS material

RECONNECT

- 016** Introducing RECONNECT
- 018** Bathrobe
- 019** Scarf
- 020** Toilet bag
- 021** Purse
- 022** Bag
- 025** Tea cosy

KITCHEN AND COOKING

- 028** Kitchen cloth
- 029** Kitchen cloth 3-pack
- 030** Display kitchen cloths
- 031** Urban kitchen cloth
- 032** Little towel
- 033** Kitchen towel
- 036** Gift set I
- 037** Gift set II
- 038** Everyday napkin
- 039** Dinner napkin
- 042** Tea cosy
- 043** Tea bag set
- 044** Mini oven mitts
- 045** Oven mitts
- 046** Apron with pocket
- 047** Creative and garden apron
- 048** Giant kitchen towel
- 049** Waist apron
- 052** Food bag set
- 053** Food bags - individually
- 055** Zero waste basic kit



BATH AND WELLNESS

- 060 Big waffle towel and blanket
- 061 Big waffle hand towel
- 062 Big waffle gift set
- 064 Big waffle bath mat
- 065 Big waffle wash cloth
- 066 Big waffle makeup pads
- 067 Big waffle bathrobe
- 070 Fine bath towel
- 071 Fine hand towel
- 072 Fine gift set
- 073 Fine wah cloth
- 075 Fine bathrobe
- 080 Wellness bathrobe
- 081 Wellness towel
- 084 Mild bath towel
- 085 Mild hand towel
- 087 Mild gift set

BAGS AND STORAGE

- 090 Big long bag
- 091 My organic bag
- 092 It matters bag
- 093 All purpose bag set
- 094 Net shoulder bag
- 095 Piqué tote bag
- 097 Net bags
- 098 Big shoulder bag
- 099 Washing bag set

RELAX AND MEDITATION

- 102 Meditation mattress to go
- 103 Meditation mattress
- 106 6-layer soft blanket
- 107 Relax and meditation cushion

REUSABLES



- 028 Kitchen cloth
- 043 Tea bag set
- 038 Everyday napkin
- 039 Dinner napkins
- 052 Food bag set
- 055 Zero waste basic kit
- 066 Big waffle makeup pads
- 091 My organic bag
- 093 It matters bag
- 093 All purpose bag set
- 094 Net shoulder bag





BORN ORGANIC

With a strong vision, Joy Vasiljev founded The Organic Company in 2007, focusing on responsible production and accountability throughout the entire value chain.

Joy is dedicated and passionate in her fight for the future of our planet - all farming must be organic, as minimum, and she believes that it is time for people to wake up, reconnect with nature and thereby live our everyday lives far more respectful and in harmony with our planet.

Joy is known as a visionary, inspiring, and uncompromising entrepreneur, who is not afraid to speak up and point out things that are not right. She has been fighting for organic and sustainable production since the very beginning and challenges all companies to take a much larger responsibility.

Her uncompromising approach is still the same today as it was in 2007.

Good intentions aren't enough. Change requires action.



Regenerative practice isn't about what comes next. It's about what must happen now. Reducing harm is no longer enough; we need to actively restore and strengthen the systems we're part of.

At The Organic Company, we see it as our responsibility not just to take less from the Earth, but to give more back; healthier soil, stronger communities, and a resilient ecosystem. That's why regenerative practice is not a choice; it's a necessity.

What do we mean when we talk about being regenerative?

Regeneration goes beyond sustainability. While sustainability is about minimizing harm, regenerative thinking is about creating positive impact. It means giving more than we take: rebuilding soil health, supporting communities, restoring ecosystems, and designing products that help nature and people thrive.

In practice, it's about asking:

How can this product support a healthier planet?

Can it last longer, be used differently, or be returned to the Earth?

Was it made in a way that nurtures the land and the people behind it?

REGENERATIVE PRACTICE - THE ONLY WAY FORWARD



ØKO SKALOTTELØG
OPR: Holland 8 kr/100g

Øko lø
opr: DK

THE ORGANIC COMPANY

ØKO JORDSKOKKER
OPR: Danmark
40 kr/kg

Øko Rødbeder
25 kr/kg
OPR: DANMARK





A REGENERATIVE SUMMER

This summer, we celebrate the quiet revolution of regenerative living. We invite you to RECONNECT with nature and its rhythm. To live more gently, choose more wisely and remember what truly matters.

A regenerative summer is a mindset. It's living with care, consuming with purpose, and reconnecting with the world around us. It's about doing what you can, with what you have, and letting those small thoughtful choices grow into something greater.

We are here to support that journey with products designed with organic materials, created to last and made with care for people and planet. Our textiles are tools for a more regenerative way of living. Beautiful, practical, and rooted in purpose.



COLOUR CONCEPT

At The Organic Company nature is more than a source of inspiration - It's our guide. Our colour palette reflects the shifting tones of the Scandinavian landscape, particularly during the darker months, where the light softens and nature slows.

From deep and rich earthy tones to muted blues and dark green, we carefully choose our colours to echo the quiet strength of nature; raw, honest and grounding.

Go earthy, go for a coordinated look, or explore contrasting colours. The choice is yours.

natural white
no. 200

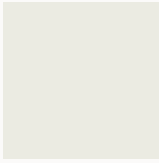

pale honey
no. 218



khaki
no. 215



stone
no. 202



clay
no. 225



dusty mint
no. 410



dark green
no. 400

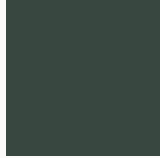

sky
no. 570

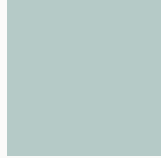

grey blue
no. 510



dark blue
no. 500



dark grey
no. 110



dusty lavender
no. 340



pale rose
no. 331



maroon
no. 390



stone khaki
no. 214



khaki stone
no. 216



volcano
no. 190



evening grey
no. 111



morning grey
no. 180

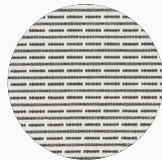

clay stone
no. 226



morning bay
no. 421



evening bay
no. 420



grey blue stone



dark blue stone



cherry blossom
no. 315

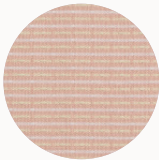

maroon stone
no. 395



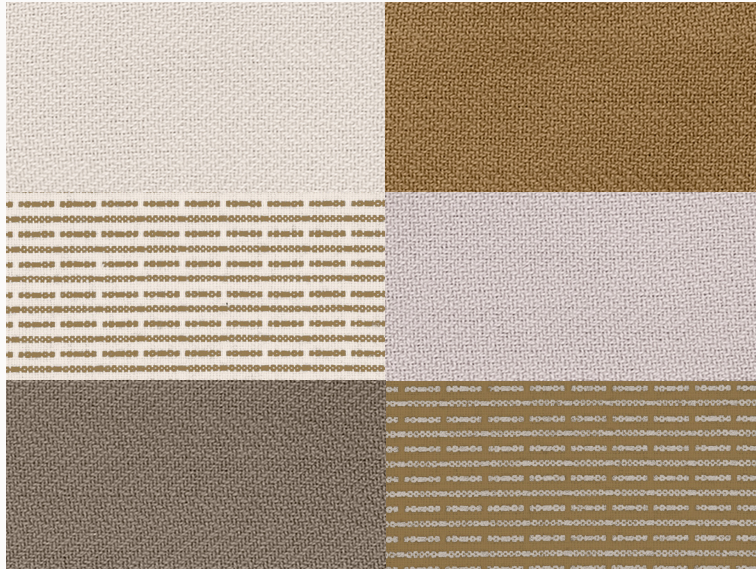

<p style="text-align: center;">stone no. 202</p>	<p style="text-align: center;">khaki no. 215</p>
<p style="text-align: center;">stone khaki no. 214</p>	<p style="text-align: center;">dusty lavender no. 340</p>
<p style="text-align: center;">clay no. 225</p>	<p style="text-align: center;">khaki stone no. 216</p>



SEASONAL COLOUR

For this season we have chosen a palette of calm and understated colours, that supports and reflects a life with a slower pace, balance and health.

The colours are carefully selected to complement one another, symbolizing togetherness and cohesion. When combined, they create a harmonious visual expression that feels warm, grounded and connected.

At the same time, the palette offers a thoughtful mix of contrasts, with each colours and texture subtly highlighting the others.

2026 / 1



LOOK BOOK

RECONNECT

INTRODUCING RECONNECT

Meet RECONNECT our new serie of everyday essentials.

The serie is about everyday items and the way we use them. With RECONNECT we wanted to design pieces that support a slower approach to everyday life and at the same time reminds us that we are all connected.

The RECONNECT series features a print designed by our founder, Joy Vasiljev, inspired by mycelium - the earth's hidden, intelligent network. This underground web plays a vital role in ecosystems, connecting and nourishing life beneath our feet.

RECONNECT will arrive this spring.



RECONNECT BATHROBE

badekåbe
bademantel
peignoir

RECONNECT is a gentle nudge to reconnect with nature and yourself. Wrapped in this bathrobe, you may pause, breathe and remember to be kind to yourself.

We hope it reminds you.

Details: Hidden pockets



pale honey
no. 218



stone
no. 202



clay
no. 225



dark blue
no. 500



Style no.	2013
Size	S/M size: 100 x 65 cm / 39.4 x 25.6" M/L size: 103 x 72 cm / 40.5 x 28.3"
Weaving	Classic weave
Dye	Organic reactive-dye print
Material	100% GOTS certified organic cotton
MOQ	2 pieces

RECONNECT SCARF

tørklæde
schal
châle

The RECONNECT Scarf is for moments:

1. after yoga
2. during meditation
3. around the shoulders on the terrace
4. around the neck whenever the urge of reconnection kicks in

Style no.	2016
Size	140 x 180 cm / "55.1 x 70.8"
Weaving	Classic weave
Dye	Organic reactive-dye print
Material	100% GOTS certified organic cotton
MOQ	2 pieces



pale honey
no. 218



stone
no. 202



clay
no. 225



dark blue
no. 500



RECONNECT TOILET BAG

toilettaske
kulturtasche
trousse de toilette

Designed to keep your essentials standing upright, so they are visible and easy to reach.

For everyone who loves to stay organized.

pale honey
no. 218



stone
no. 202



clay
no. 225



dark blue
no. 500



Style no.	2017
Size	28 x 16 x 13 cm / 11 x 6.3 x 5.1"
Weaving	Classic weave
Dye	Organic reactive-dye print
Material	100% GOTS certified organic cotton
MOQ	4 pieces

RECONNECT PURSE

pung
kleine tasche
pochette

When you are in your makeup or creative zone, you want everything within reach. Use the purse for your everyday essentials, so you can focus, uninterrupted.

Small, lightweight and easy to take with you.



pale honey
no. 218



stone
no. 202



clay
no. 225



dark blue
no. 500



Style no.	2016
Size	28 x 16 cm / 11 x 6.3"
Weaving	Classic weave
Dye	Organic reactive-dye print
Material	100% GOTS certified organic cotton
MOQ	4 pieces



RECONNECT BAG

taske
tasche
sac

Roomier than a tote, but not as large as a weekend bag. It's just right for daily essentials.

It's designed to be effortlessly casual, yet stylish, with a neat lining for a refined finish.

Style no.	2014
Size	45 x 35 x 20 cm / 17.7 x 13.8 x 7.8"
Weaving	Classic weave
Dye	Organic reactive-dye print
Material	100% GOTS certified organic cotton
MOQ	4 pieces



pale honey
no. 218



stone
no. 202



clay
no. 225



dark blue
no. 500







RECONNECT TEA COSY

tehætte
tekannehaube
couvre-théière

Proper tea brewing with loose leaves is slow living and an opportunity to reconnect with yourself and the present moment. Enjoy it, and remember to value all the small pauses.

The tea cosy makes sure that your tea pot keeps a good temperature. It is made with insulating cotton wadding in pure and certified organic cotton.



pale honey
no. 218



stone
no. 202



clay
no. 225



dark blue
no. 500



Style no.	2018
Size	30 x 18 cm / 11.8 x 7" (four sides)
Weaving	Classic weave /
Dye	Organic reactive-dye print
Material	100% GOTS certified organic cotton
MOQ	4 pieces





Soft to the touch, gentle on surfaces, and kind to the planet. Our organic **kitchen and cooking** textiles are carefully crafted from 100% GOTS-certified organic cotton grown without harmful chemicals, supporting soil health and biodiversity. To reduce waste our textiles are made to last through countless washes and daily use.

Born from nordic minimalism our designs embrace simplicity, functionality and timeless elegance. Guided by the principle of “less but better” each piece is thoughtfully designed with clean lines, neutral tones and a refined aesthetic that never goes out of style.

From careful design to thoughtful production, each piece contributes to a more regenerative way of living – kind to the planet, the people who make it, and the home you bring it into.

2026 / 1

LOOK BOOK

KITCHEN AND COOKING



KITCHEN CLOTH



karklud
abwaschtuch
serviette de invitée

Use this kitchen cloth to wipe away water and crumbs from your table and counter top. Also a great cloth for cleaning around the house.

This reusable cloth can easily replace many rolls of paper towels and single use cloths. Fast drying with great absorbency. Integrated strap for hanging.

Our Kitchen cloth is voted "best in test".



Style no.	1048
Size	30 x 35 cm / 11.8 x 13.8"
Weaving	Piqué
Material	100% GOTS certified organic cotton
MOQ	12 pieces

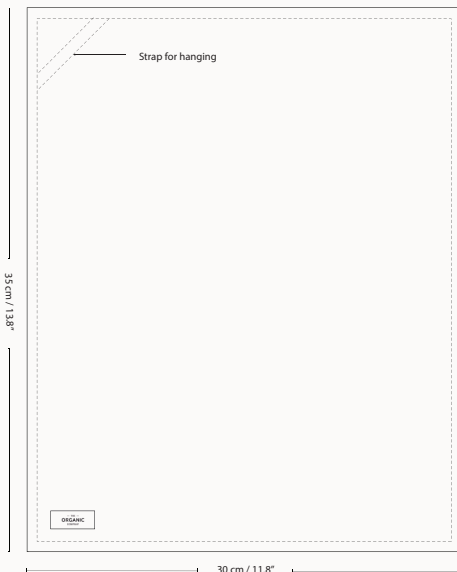

stone khaki
no. 214



khaki stone
no. 216



volcano
no. 190



clay stone
no. 226



morning bay
no. 421



evening bay
no. 420



grey blue stone
no. 511



dark blue stone
no. 550



evening grey
no. 111



morning grey
no. 180



cherry blossom
no. 315



maroon stone
no. 395



KITCHEN CLOTH 3 PACK



B
U
N
D
L
E
O
F
F
E
R

karklud
abwaschtuch
serviette de invitée

The Kitchen cloth has a unique ability to absorb liquid - isn't it the most important thing a dish cloth should be able to do?

Set of three pieces for easy and frequent change.

Style no.	1139
Size	30 x 35 cm / 11.8 x 13.8", 3-pack
Weaving	Piqué
Material	100% GOTS certified organic cotton
MOQ	8 sets of 3 pieces

OCEAN SET no. 912

morning grey
no. 180



grey blue stone
no. 511



dark blue stone
no. 550



MORNING GREY SET no. 180

morning grey
no. 180



morning grey
no. 180



morning grey
no. 180



EARTH SET no. 911

clay stone
no. 226



stone khaki
no. 214



evening grey
no. 111



EVENING GREY SET no. 111

evening grey
no. 111



evening grey
no. 111



evening grey
no. 111



CLAY STONE SET no. 226

clay stone
no. 226



clay stone
no. 226



clay stone
no. 226



DISPLAY KITCHEN CLOTH



B
U
N
D
L
E
O
F
F
E
R

karklud
abwaschtuch
serviette de invitée

This reusable cloth can easily replace many rolls of paper towels and single use cloths. Fast drying with great absorbency. Integrated strap for hanging.

Our Kitchen cloth is voted "best in test".

Buy one display box and get eight kitchen cloths for free.



Style no. 1097
Size 30 x 35 cm / 11.8 x 13.8",
display box with 48 pieces
Weaving Piqué
Material 100% GOTS certified organic cotton
MOQ One display box of 48 pieces

EARTH BOX
no. 931

clay stone
no. 226

stone khaki
no. 214

khaki stone
no. 216

CLASSIC BOX
no. 930

morning grey
no. 180

clay stone
no. 226

evening grey
no. 111



URBAN KITCHEN CLOTH

karklud
abwaschtuch
serviette de invitée

The Urban kitchen cloth is designed for urban citizens and their kitchens.

Customized in size for tighter urban spaces.

Set of three pieces for easy and frequent change.

Woven in our absorbent, fast drying and unique pique weave, like our best-selling and larger-sized classic kitchen cloth awarded 'Best in Test'.



khaki stone
no. 216



clay stone
no. 226



grey blue stone
no. 511



evening grey
no. 111



morning grey
no. 180



Style no.	1164
Size	18 x 35 cm / 7.1 x 13.8"
Weaving	Piqué
Material	100% GOTS certified organic cotton
MOQ	4 sets of 3 pieces

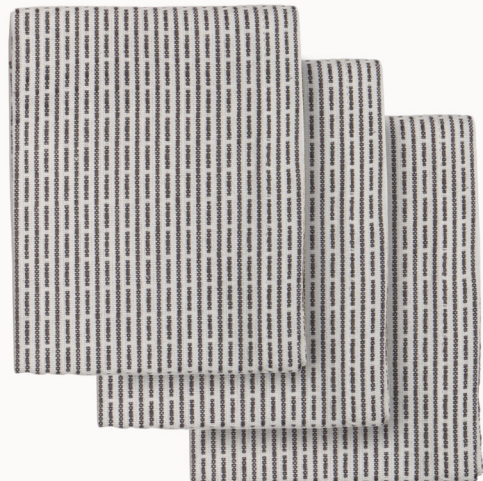

LITTLE TOWEL

håndklæde
handtuch
essuie-mains

A little towel for use in the kitchen.

Designed with high absorbency for daily situations.

A beautiful combination of design and functionality.



Style no.	1078
Size	35 x 60 cm / 13.7 x 23.6"
Weaving	Piqué
Material	100% GOTS certified organic cotton
MOQ	8 pieces

stone khaki
no. 214



khaki stone
no. 216



volcano
no. 190



clay stone
no. 226



morning bay
no. 421



evening bay
no. 420



grey blue stone
no. 511



dark blue stone
no. 550



evening grey
no. 111



morning grey
no. 180



cherry blossom
no. 315



maroon stone
no. 395



KITCHEN TOWEL

viskestykke
geschirhandtuch
torchon

An extra large kitchen towel that is designed to absorb, to last and look great. Use the integrated straps to hang up your kitchen towel.

Our Kitchen towel is voted "best in test".

Style no. 1041
Size 53 x 86 cm / 20.8 x 33,8"
Weaving Herringbone
Material 100% GOTS certified organic cotton
MOQ 8 pieces



natural white
no. 200



pale honey
no. 218



khaki
no. 215



stone
no. 202



clay
no. 225



dusty mint
no. 410



dark green
no. 400



sky
no. 570



grey blue
no. 510



dark blue
no. 500



dusty lavender
no. 340



pale rose
no. 331



maroon
no. 390



dark grey
no. 110

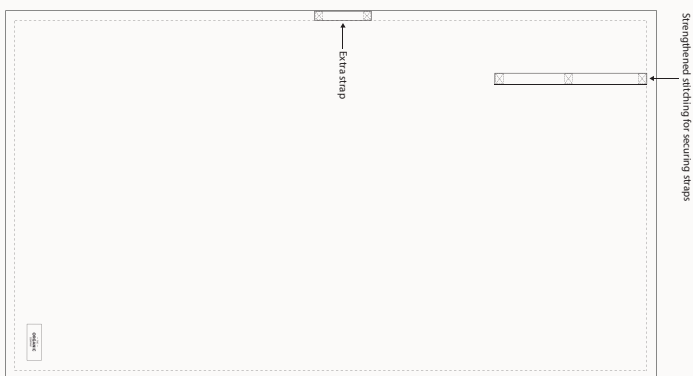

WHY FUNCTIONAL DESIGN IS IMPORTANT TO US

When designing our products, attention to detail and great functionality is key to creating LONG LASTING quality products.

An example of this is our kitchen towel.



Organic herringbone cotton weave



great absorbency, will actually dry your dishes

We have added extra straps



flexibility on where and how to hang

Strengthened stitching on straps



long lasting, it's (almost) impossible to tear apart

It is the small things that make the difference. Something we keep in mind when designing all our products.

Our kitchen towel has even won "best in test" twice.



KITCHEN TOWEL DETAILS

Strengthened stitching for securing straps

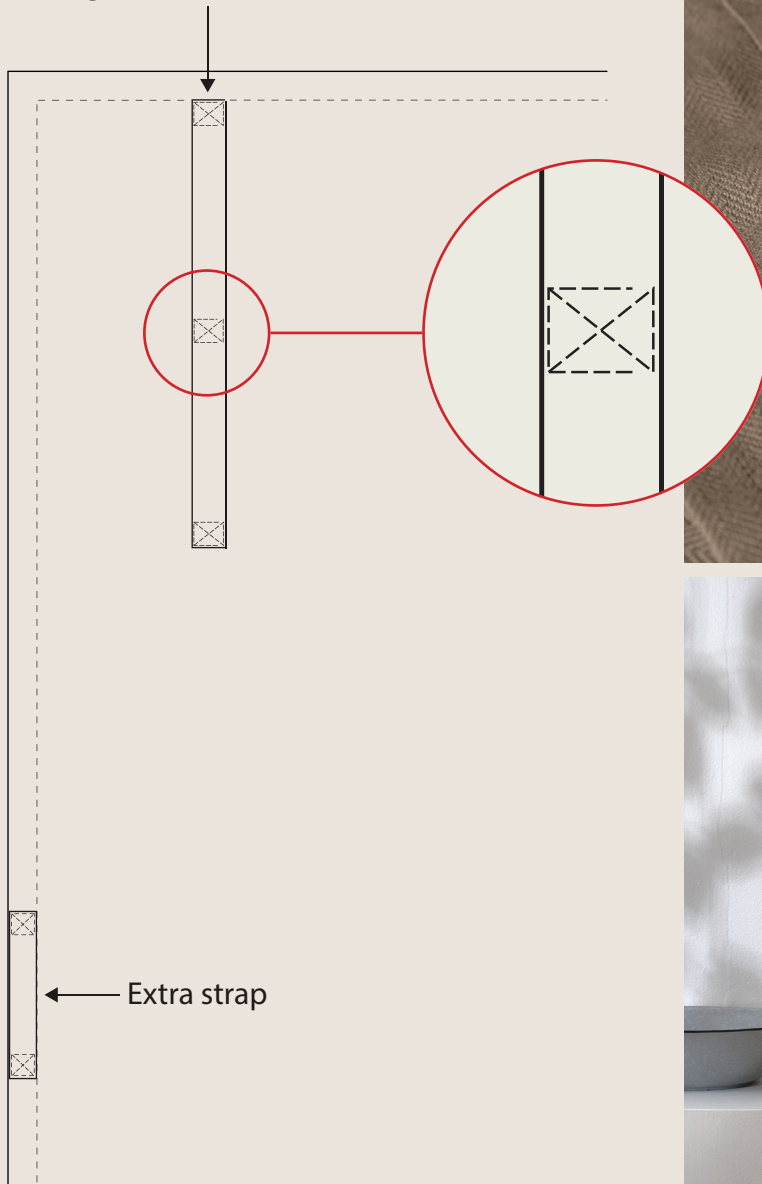

GIFT SET I

gavesæt
geschenkset
coffret cadeau

A twin set of two kitchen towels.

An extra large kitchen towel that is designed to absorb, to last and look great. Use the integrated straps to hang up your kitchen towel.

Our Kitchen towel is voted "best in test".

Style no.	1086
Size	One set of two kitchen towels, 53 x 86 cm / 20.8 x 33.8"
Weaving	Herringbone
Material	100% GOTS certified organic cotton
MOQ	8 sets

EARTH MIX
no. 951

khaki
no. 215



clay
no. 225



OCEAN MIX
no. 953

grey blue
no. 510



dark blue
no. 500



CLASSIC MIX
no. 954

dark grey
no. 110



stone
no. 202



GIFT SET II

gavesæt
geschenkset
coffret cadeau

A set consisting of two kitchen cloths and one kitchen towel. Presentable, colour coordinated and ready to be used.

Our gift set II is also a long lasting gift set for many occasions.

Style no.	1087
Size	One gift set contains one kitchen towel, 53 x 86 cm / 20.8 x 33,8" and two kitchen cloths, 30 x 35 cm / 11.8 x 13.8"
Weaving	Piqué and herringbone
Material	100% GOTS certified organic cotton
MOQ	8 sets



EARTH SET
no. 971

clay
no. 225

clay stone
no. 226

khaki stone
no. 216

OCEAN SET
no. 973

grey blue
no. 510

grey blue stone
no. 511

dark blue stone
no. 550

CLASSIC SET
no. 974

dark grey
no. 110

morning grey
no. 180

evening grey
no. 111



EVERYDAY NAPKIN



serviet
stoffserviette
serviette

Millions of trees every year are used for single-use purposes. Amongst other, as paper towels and paper napkins. Let's reuse much more.

Our Everyday napkin is designed as a practical and nice piece to replace disposable paper in many everyday situations.

What is your choice?

Comes in a box with four napkins.

Style no.	1073
Size	20 x 20 cm / 7.9 x 7.9", box of four pieces
Weaving	Herringbone
Material	100% GOTS certified organic cotton
MOQ	8 boxes of 4 napkins

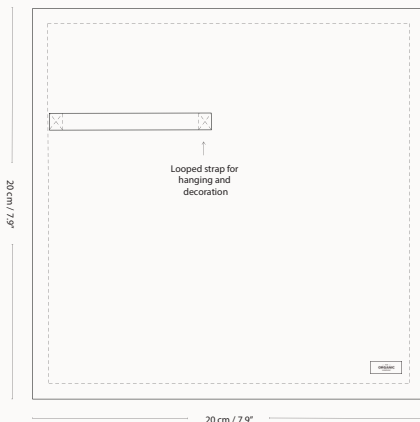

- natural white**
no. 200 
- stone**
no. 202 
- clay**
no. 225 
- khaki**
no. 215 
- earth color mix**
no. 901 
- dusty mint**
no. 410 
- dark green**
no. 400 
- grey blue**
no. 510 
- dark blue**
no. 500 
- dusty lavender**
no. 340 
- maroon**
no. 390 
- dark grey**
no. 110 

DINNER NAPKINS



serviet
stoffserviette
serviette

Millions of trees every year are used for single-use purposes. Amongst other, as paper towels and paper napkins. Let's reuse much more.

Our Dinner napkin is designed as a practical and nice piece to replace disposable paper in many everyday situations.

What is your choice?

Comes in a box with four napkins.



natural white
no. 200



stone
no. 202



clay
no. 225



dusty mint
no. 410



dark green
no. 400



dark grey
no. 110



Style no.	1134
Size	35 x 40 cm / 13.8 x 15.7", box of four pieces
Weaving	Herringbone
Material	100% GOTS certified organic cotton
MOQ	8 boxes of 4 napkins

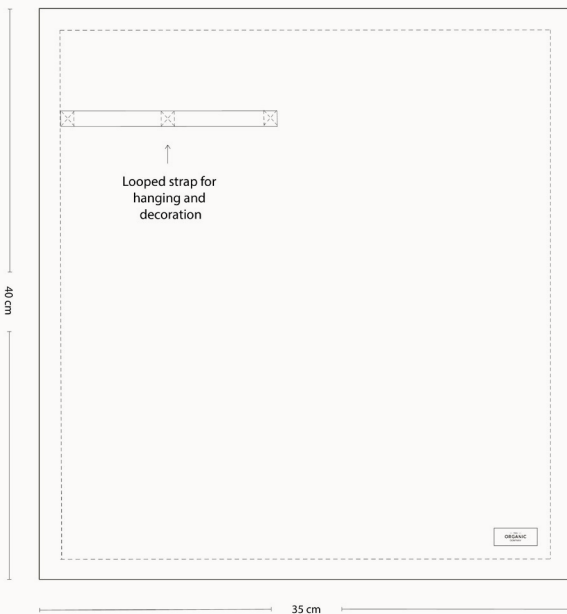





Rethink waste

Reuse what you already have at home. Try a reusable napkin instead of a paper napkin or a reusable cloth instead of single-use. Regeneration starts at home.

TEA COSY

tehætte
tekannehaube
couvre-théière

Enjoy your tea and keep it warm for longer.

This tea cosy is made with insulating cotton wadding in pure and certified organic cotton.

Delicate yet practical - as part of our range of great kitchen accessories.

Style no. 1034
Size 36 x 30 cm / 11.8 x 14.2"
Weaving Piqué cotton wadding
Material 100% GOTS certified organic cotton
MOQ 4 pieces



khaki stone
no. 216



volcano
no. 190



clay stone
no. 226



evening grey
no. 111

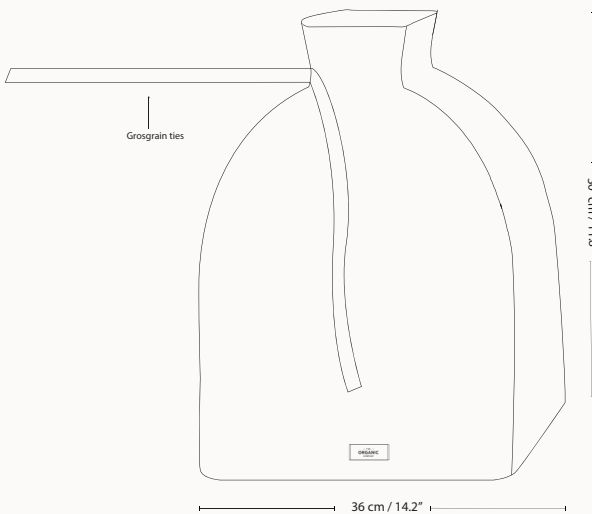

TEA BAG SET



undyed
no. 201



tepose
teebeutel
sachet de thé

Did you know that millions of tea bags are used once and dumped daily?

Replace single-use tea bags and enjoy your favorite tea in this reusable tea bag. Made in organic food- approved and unbleached cotton for a cleaner cup of tea.

What is your choice?



Style no.	1070
Size	Box of one small and one medium bag, one teak tree stick (wastage)
Weaving	Plain voile
Material	100% GOTS certified organic cotton / food-approved material
MOQ	8 boxes

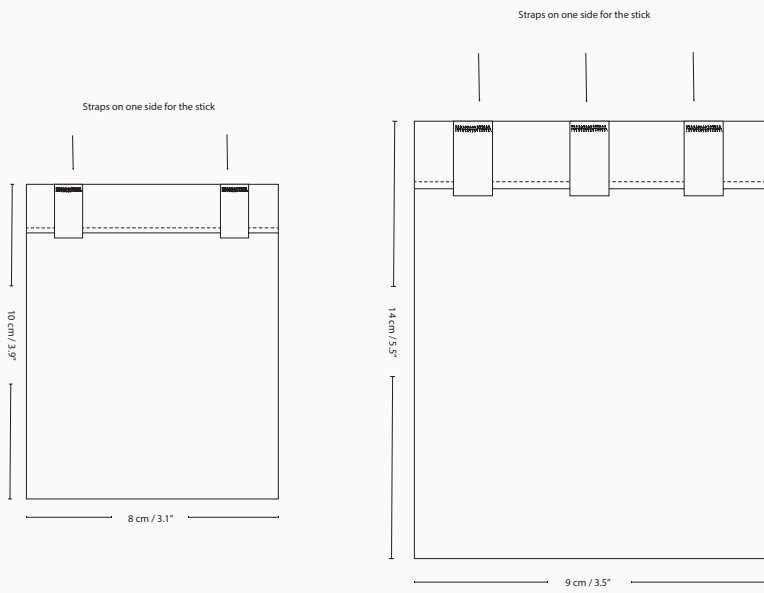

MINI OVEN MITTS

ovnhandsker
ofenhandschuhe
gants de cuisine

Small and convenient oven mitts, that does not take up much space. Easy and quick way to protect your hands while working with heat in the kitchen. With a distinct design and in 100% organic cotton.

Set of two oven mitts.



clay stone
no. 226



volcano
no. 190



grey blue stone
no. 511



dark blue stone
no. 550



evening grey
no. 111



dark grey
no. 110



Style no.	1189
Size	14 x 14 cm / 5.5 x 5.5"
Weaving	Piqué or herringbone, cotton wadding
Material	100% GOTS certified organic cotton
MOQ	4 pieces

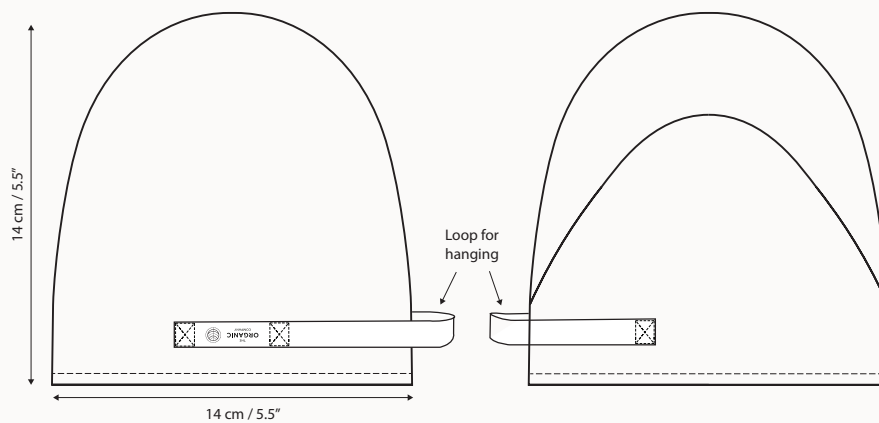

OVEN MITTS

ovnhandsker
ofenhandschuhe
gants de cuisine

When cooking delicious food, your kitchen accessories need to be in order. Protect your hands and arms while working with heat in the kitchen - and do this with distinct design and in 100% organic cotton.

Our oven mitts have been tested and approved to withstand heat for up to 662 degrees Fahrenheit / 350 degrees centigrades.

Style no.	1045
Size	15 x 31 cm / 5.9 x 12.2"
Weaving	Canvas, cotton wadding
Material	100% GOTS certified organic cotton
MOQ	4 pieces



khaki
no. 215



grey blue
no. 510



ONE SIZE

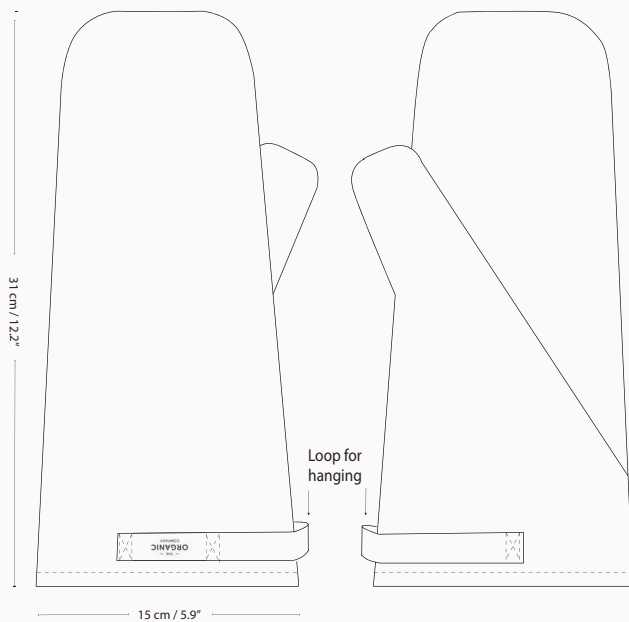

APRON WITH POCKET

forklæde
schürze
tablier

A practical apron in many different situations; cooking at home, servicing customers, cleaning.



clay
no. 225



dark grey
no. 110



dark green
no. 400



grey blue
no. 510



dark blue
no. 500



Style no.	1037
Size	80 x 95 cm / 31.5 x 37.4"
Weaving	Twill drill
Material	100% GOTS certified organic cotton
MOQ	4 pieces

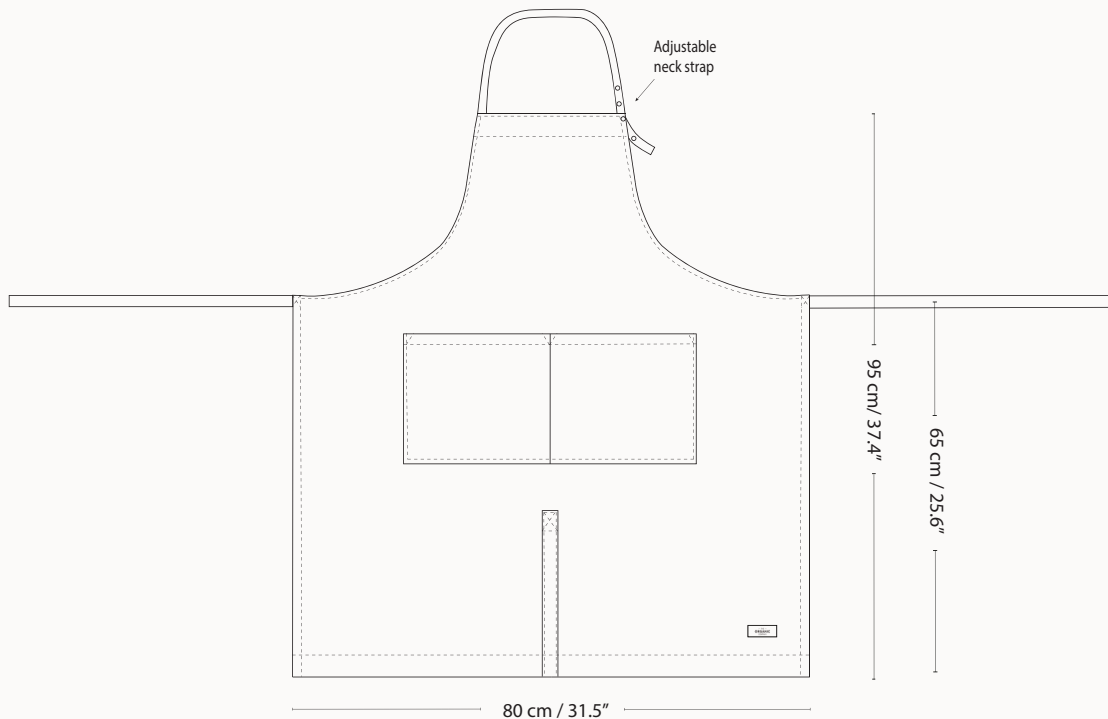

CREATIVE AND GARDEN APRON

forklæde
schürze
tablier

Backyard, studio, kitchen... wherever you are, this apron has you covered.

It's made from 100% certified organic cotton, in a canvas weave that's tough enough for even your most messy projects.

Comes with five practical pockets to keep your tools close at hand.

Style no.	1031
Size	100 x 74 cm / 39.4 x 29.0"
Weaving	Canvas
Material	100% GOTS certified organic cotton
MOQ	4 pieces



clay
no. 225



dark grey
no. 110



dark green
no. 400



grey blue
no. 510



dark blue
no. 500

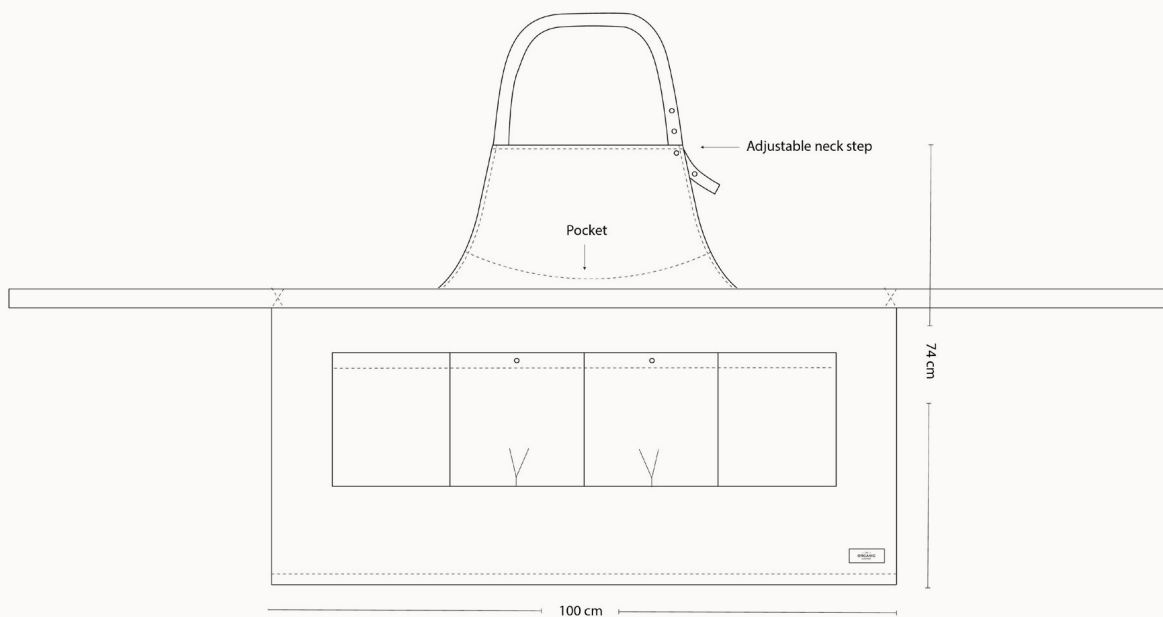

GIANT KITCHEN TOWEL

forklæde
schürze
tablier

Use our Giant kitchen towel for your dishes or wrap it around you to look nice and practical when you cook, bake or grill.

Designed to be practical.



clay
no. 225



dusty mint
no. 410



grey blue
no. 510



dusty lavender
no. 340



dark grey
no. 110



Style no.	1039
Size	60 x 155 cm / 23.6 x 61.0"
Weaving	Herringbone
Material	100% GOTS certified organic cotton
MOQ	4 pieces

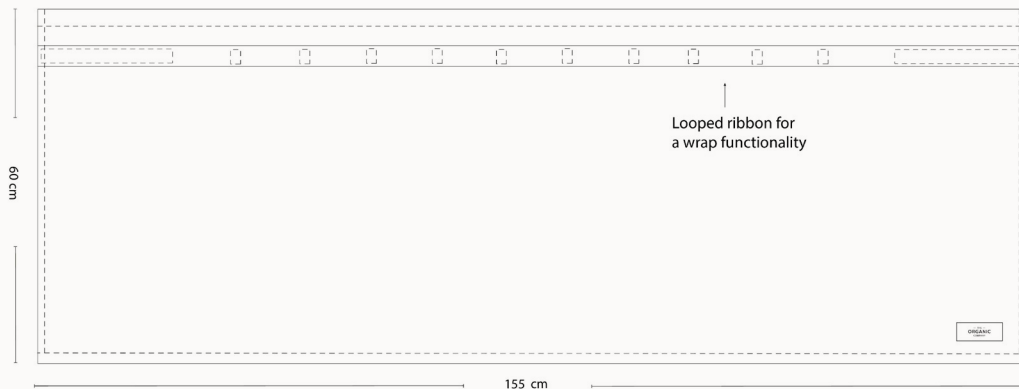

WAIST APRON

forklæde
schürze
tablier

Inspired by the Japanese minimalism and decorative food preparation, we have designed this waist apron for professionals and for the rest of us that wants to protect our clothes while preparing food to be served beautifully.

pale honey
no. 218



clay
no. 225



dark grey
no. 110



dark green
no. 400



Style no.	2000
Size	83 x 100 cm / 32.7 x 39.4"
Weaving	Twill drill
Material	100% GOTS certified organic cotton
MOQ	4 pieces

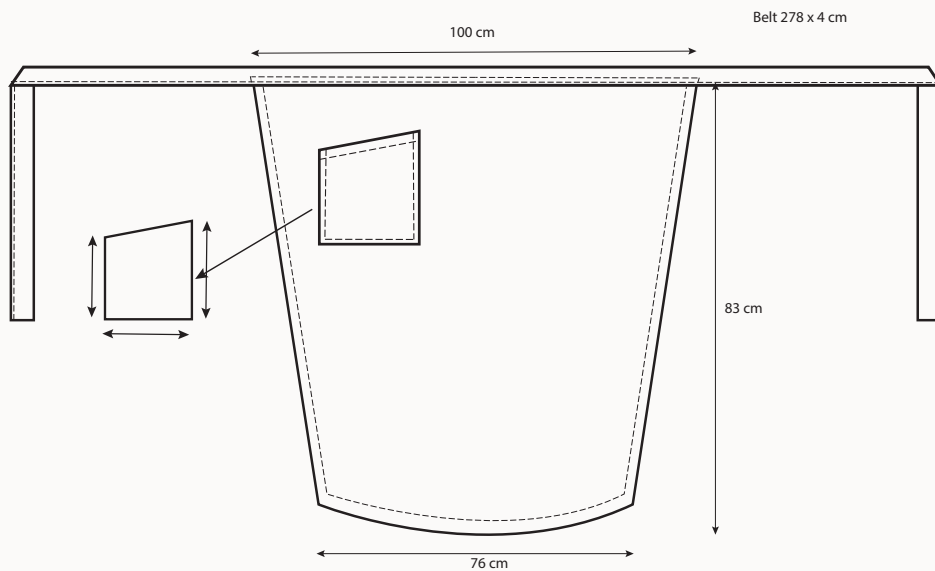



— THE —
ORGANIC
COMPANY



Local, Seasonal, Sustainable

Eating seasonal and locally grown food not only taste better, it also lowers your CO₂ impact and strengthens local communities. Small choices make a big difference.

FOOD BAG SET



madpose
essenbeutel
sac de nourriture

The Food Bag is designed with special care for people and the environment. The bag is a reusable alternative to disposable packaging.

Use it for shopping and storing bulk goods like fruit and vegetables.

String for hanging, carrying and closure.
Made in organic food-approved cotton.



natural white
no. 200



stone
no. 202



khaki
no. 215



dark green
no. 400



maroon
no. 390



SET OF 3

Style no.

1116

Size

One small: 16 x 22 x 6 cm / 2.3 x 6.3 x 8.7"
One medium: 24 x 30 x 8 cm / 3.1 x 9.4 x 11.8"
One large: 30 x 40 x 12 cm / 4.7 x 11.8 x 15.7"

Weaving

Gauze

Material

100% GOTS certified organic cotton / food-approved material

MOQ

8 sets

label for weight info
attached inside the bag

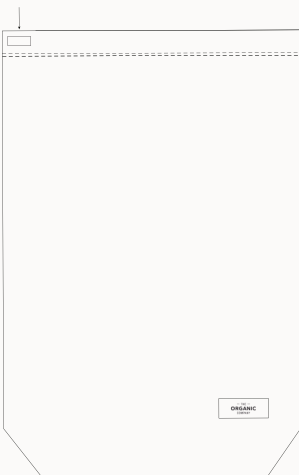

String

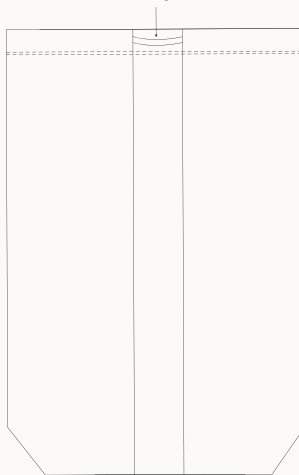

FOOD BAG

madpose
essenbeutel
sac de nourriture

Did you know that we use around 2 million single use plastic bags every minute, on a global scale?

Replace plastic and have your food contained organically with our food bags. Made in organic food-approved cotton.

What is your choice?



natural white
no. 200



stone
no. 202



khaki
no. 215



dark green
no. 400



maroon
no. 390



SMALL

Style no. 1049
Size 16 x 22 x 6 cm / 2.3 x 6.3 x 8.7"
Weaving Gauze
Material 100% GOTS certified organic cotton / food-approved material
MOQ 16 pieces

LARGE

Style no. 1051
Size 30 x 40 x 12 cm / 11.8 x 15.7 x 4.7"
Weaving Gauze
Material 100% GOTS certified organic cotton / food-approved material
MOQ 16 pieces

MEDIUM

Style no. 1050
Size 24 x 30 x 8 cm / 9.4 x 11.8 x 3.1"
Weaving Gauze
Material 100% GOTS certified organic cotton / food-approved material
MOQ 16 pieces





ZERO WASTE BASIC KIT



B
U
N
D
L
E
O
F
F
E
R

CLASSIC SET COLOUR MIX
no. 954

natural white
no. 200



stone
no. 202



dark grey
no. 110



evening grey
no. 111



The best way to reduce waste is to cut out single use items in our life.

We have collected a mix of 6 of our bestselling reusable items for everyday zero wasting. Thank you for challenging the single use culture.

Style no. 1186
Weaving Miscellaneous
Material 100% GOTS certified organic cotton
MOQ 4 pieces



With our **bath and wellness** collection you can turn simple routines into calming moments of care. Whether it's the chunky texture of BIG WAFFLE, the warm embrace of MILD, the light touch of FINE or the mindful comfort of our WELLNESS line, each collection is design to engage the senses and bring balance to your day.

By choosing textiles that both feel good and last long you bring a little bit of regenerative living into your home honoring both your well-being and the nature. This summer, let your bathroom be the space where small mindful choices help you live gently and in rhythm with nature.



2026 / 1



LOOK BOOK

BATH AND WELLNESS





BIG WAFFLE INTRO

BIG WAFFLE is our soft, chunky bath series. It is designed for comfort and crafted for everyday use. Made from pure, organic cotton, the texture weave feels plush and absorbent, wrapping you in warmth straight from the shower.

The signature waffle structure, also known as a honeycomb weave, creates a three-dimensional surface of gently raised squares inspired by the classic Belgian waffle. This weaving technique not only adds depth and character, but also enhances softness and absorbency.

With its cozy texture and clean nordic lines, BIG WAFFLE brings a sense of calm and balance to your bathroom. Mix and match colours and styles with pieces from our FINE, WELLNESS, or MILD collections for a soft layered expression. A mix of tones, textures and weaves that feels personal, lived-in and perfectly imperfect.



BIG WAFFLE TOWEL AND BLANKET

håndklæde
handtuch
serviette de bain

This towel is more than a large and distinct towel with great absorbency. It is also a thick and comfortable blanket for yoga, the beach and on the terrace.

Integrated strap for hanging.

Style no. 1029
Size 100 x 150 cm / 39.4 x 59.0"
Weaving Waffle
Material 100% GOTS certified organic cotton
MOQ 4 pieces



natural white
no. 200



stone
no. 202



clay
no. 225



dusty lavender
no. 340



dark grey
no. 110



grey blue
no. 510

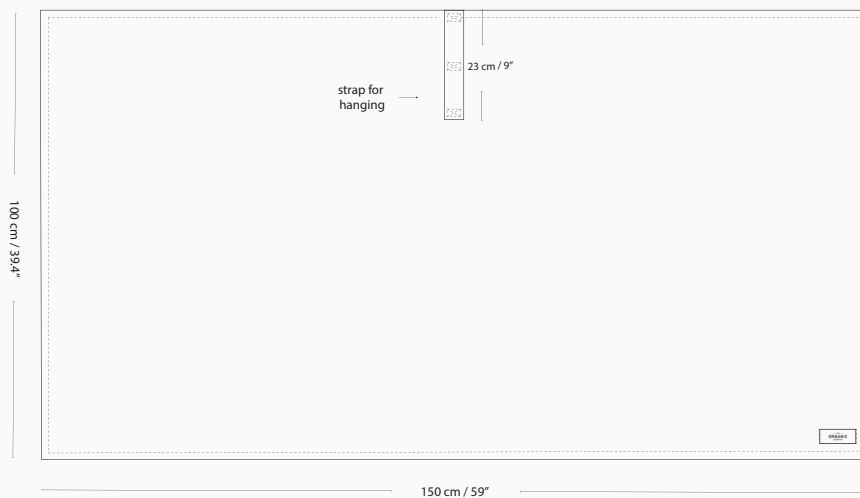

BIG WAFFLE HAND TOWEL

håndklæde
handtuch
serviette de bain

This piece was developed to make a soft and comfortable guest and hand towel with a designed expression.

Great absorbency.

Integrated strap for hanging.

Style no.	1020
Size	50 x 75 cm / 19.7 x 29.5"
Weaving	Waffle
Material	100% GOTS certified organic cotton
MOQ	4 pieces



natural white
no. 200



stone
no. 202



clay
no. 225



dusty lavender
no. 340



dark grey
no. 110



grey blue
no. 510

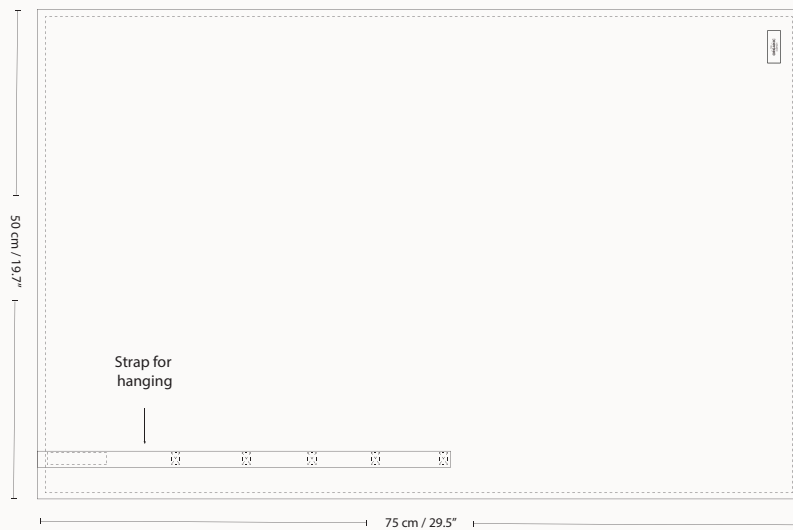

BIG WAFFLE GIFT SET

gavesæt
geschenkset
coffret cadeau

Our Big waffle gift set is perfect for that special someone.

A timeless and long lasting gift set for many occasions. Presentable, thoughtful and sustainably made in pure organic cotton.

The Big waffle gift set consists of one large Big waffle towel and blanket and one Big waffle hand towel.

natural white
no. 200



stone
no. 202



clay
no. 225



dark grey
no. 110



Style no.	1194
Size	A gift set contains: One towel and blanket 100 x 150 cm / 39.4 x 59.0" One hand towel, 50 x 75 cm / 19.7 x 29.5"
Weaving	Waffle
Material	100% GOTS certified organic cotton
MOQ	2 sets





BIG WAFFLE BATH MAT

bademåtte
badematte
tapis de bain

Our bath mat combines the comforting feeling when stepping out of the bath with a modern and relaxed expression.

The mat can easily be hung in the strap.



natural white
no. 200



stone
no. 202



clay
no. 225



dusty lavender
no. 340



dark grey
no. 110



grey blue
no. 510



Style no.	1026
Size	80 x 55 cm / 21.7 x 31.5"
Weaving	Waffle
Material	100% GOTS certified organic cotton
MOQ	4 pieces

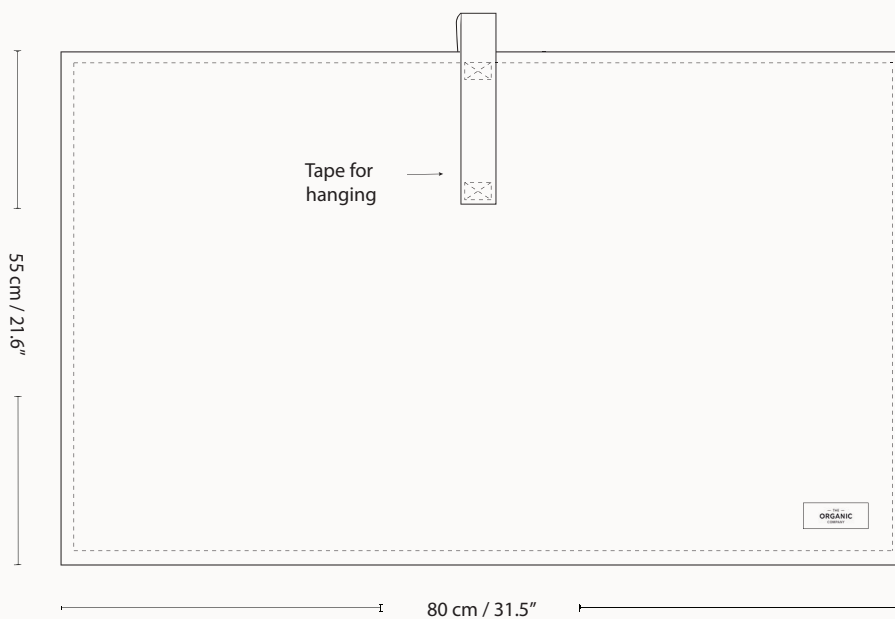

BIG WAFFLE WASH CLOTH

vaskeklud
waschlappen
serviette de invitée

An absorbent cloth for personal care or a distinct guest towel. With a functional strap for hanging.

A good-looking piece great in action.

Package of 3 cloths.



natural white
no. 200



stone
no. 202



clay
no. 225



dusty lavender
no. 340



dark grey
no. 110



grey blue
no. 510



Style no.	1190
Size	25 x 40 cm / 9.8 x 15.7"
Weaving	Waffle
Material	100% GOTS certified organic cotton
MOQ	4 pieces

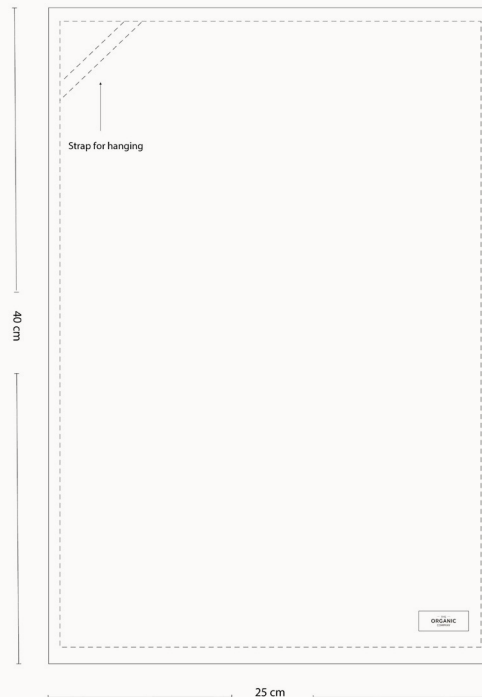

BIG WAFFLE MAKEUP PADS



rondeller
kosmetikpads
tampons démaquillants

It all came together.
To use leftover fabric from our towel
production to make soft and reusable pads
for facial care and makeup removal. So
much better than single use cotton pads.

What is your choice?

Comes in a box with four makeup pads.



natural white
no. 200



stone
no. 202



clay
no. 225



dusty lavender
no. 340



dark grey
no. 110



grey blue
no. 510



Style no.	1017
Size	Box of two square (8 x 8 cm / 3.1 x 3.1") and two oval pieces (7 x 11 cm / 2.5 x 4.3")
Weaving	Waffle
Material	100% GOTS certified organic cotton
MOQ	8 boxes

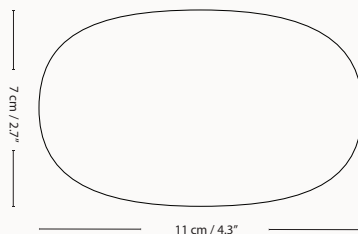
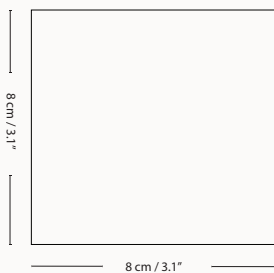

BIG WAFFLE BATHROBE

badekåbe
bademantel
peignoir

Enjoy a quiet and relaxed feeling when wrapping yourself in our soft and cosy bathrobe. Use it at home, at the spa and when travelling.

Designed with a comfortable fit and made in our favourite Big Waffle weaving. Double loops on the back help the belt stay in place and according to your preference.

Woven from certified organic cotton, naturally.

New feature on dark grey bathrobe: inner pocket.

Style no.	1143
Size	S/M size: 119 x 63 cm / 46,9" x 24.8" M/L size: 128 x 68 cm / 50.4" x 26.8"
Weaving	Waffle
Material	100% GOTS certified organic cotton
MOQ	2 pieces



natural white
no. 200



stone
no. 202



dark grey
no. 110

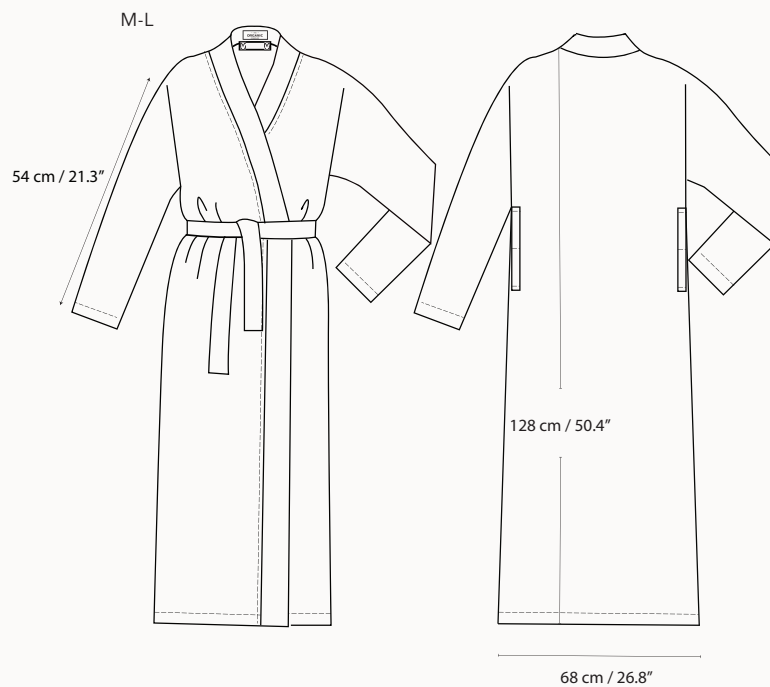



FINE INTRO

FINE captures the essence of nordic traditions with light materials and soft tones. It's designed to be an airy, light and "flowy" towel for your hands, body and hair.

Crafted in three layers of fine, lightweight gauze FINE towels combine freedom and functionality in an uncommonly soft and fast-drying fabric. The featherlight design makes them easy to roll up and take with you to the ocean, the sauna or simply moving through your day.

FINE is a feeling of lightness, softness and every day ease.



FINE BATH TOWEL

håndklæde
handtuch
serviette de bain

Experience freedom and weightlessness with the combination of 3 layers of lightweight gauze, soft colour tones and unconventional towel sizes for your hands, hair and body. Light, beautiful, and fast drying.

A bath towel with a true and pure flowy feeling.

Style no. 1130
Size 100 x 150 cm / 39.4 x 59.0"
Weaving Gauze
Material 100% GOTS certified organic cotton
MOQ 4 pieces



pale honey
no. 218



stone
no. 202



clay
no. 225



dusty lavender
no. 340



dusty mint
no. 410



grey blue
no. 510

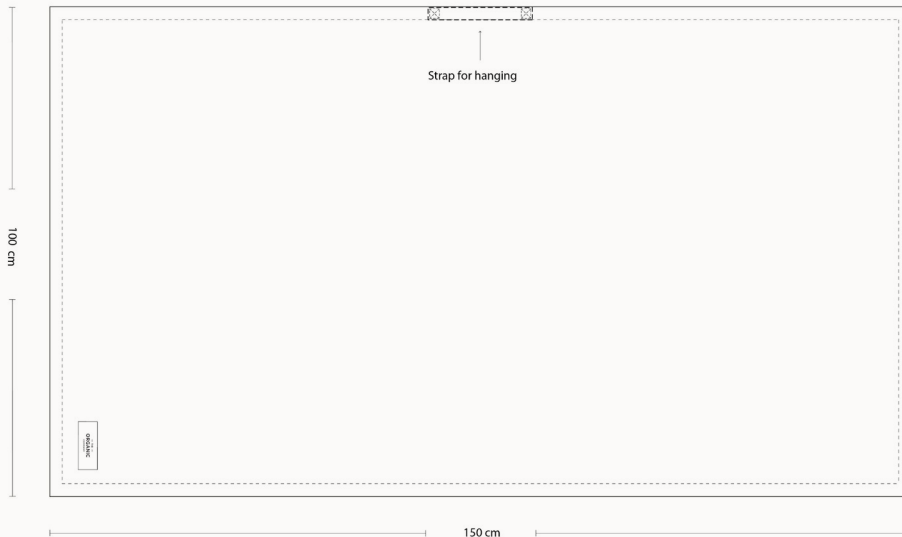

FINE HAND TOWEL

håndklæde
handtuch
serviette de bain

Experience freedom and weightlessness with the combination of 3 layers of lightweight gauze, soft colour tones and unconventional towel sizes for your hands, hair and body. Light, beautiful, and fast drying.

A hand towel with a true and pure flow feeling.

Style no. 1131
Size 60 x 100 cm / 23.6 x 39.4"
Weaving Gauze
Material 100% GOTS certified organic cotton
MOQ 4 pieces



pale honey
no. 218



stone
no. 202



clay
no. 225



dusty lavender
no. 340



dusty mint
no. 410



grey blue
no. 510

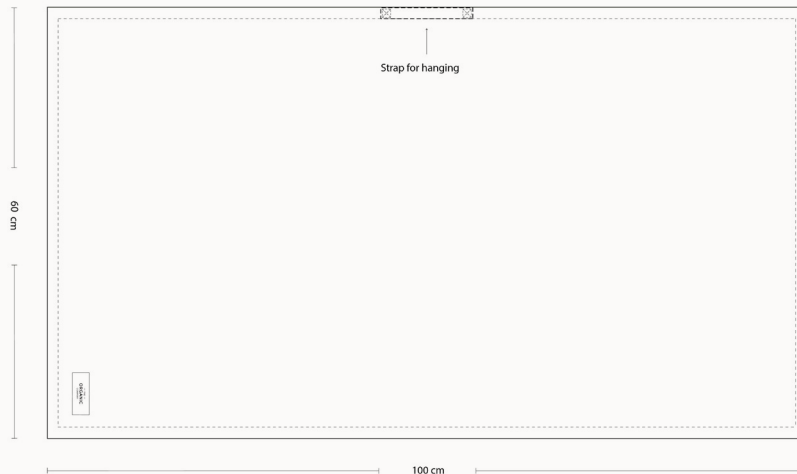

FINE GIFT SET

gavesæt
geschenkset
coffret cadeau

Our FINE gift set is perfect for that special someone.

A timeless and long lasting gift set for many occasions. Presentable, thoughtful and sustainably made in pure organic cotton.

The FINE gift set consists of one FINE bath towel and one FINE hand towel.

pale honey
no. 218



stone
no. 202



clay
no. 225



dusty lavender
no. 340



dusty mint
no. 410



grey blue
no. 510



Style no.	1183
Size	A gift set contains: One hand towel 60 x 100 cm / 23.6 x 39.4" One bath towel 100 x 150 cm / 39.4 x 59.0"
Weaving	Gauze
Material	100% GOTS certified organic cotton
MOQ	4 sets



FINE WASH CLOTH

vaskeklud
waschlappen
serviette de invitée

Experience freedom and weightlessness with the combination of 3 layers of lightweight gauze and soft colour tones.

A cloth with a flowy feeling for personal care. Light, beautiful, and fast drying.

Package of 3 cloths.

Style no.	1199
Size	30 x 30 cm / 11,8 x 11,8"
Weaving	Gauze
Material	100% GOTS certified organic cotton
MOQ	4 pieces

pale honey
no. 218



stone
no. 202



clay
no. 225



dusty lavender
no. 340



dusty mint
no. 410



grey blue
no. 510





FINE BATHROBE

badekåbe
bademantel
peignoir

Made for a nice home feeling or to bring to the SPA or other wellness treats.

With sleeves three-quarter length og hidden pockets.

3 layers of fine, lightweight organic gauze.

stone
no. 202



clay
no. 225



Style no.	1191
Size	S/M size: 65 x 100 cm / 25.6 x 39.4" M/L size: 72 x 103 cm / 28,3 x 39.4"
Weaving	Gauze
Material	100% GOTS certified organic cotton
MOQ	2 sets





Respect the fibers

Caring for your textiles means caring for the planet. Air-dry your towels and wash only when needed. That will not only extend your textiles life, but also save water and energy. It's a simple yet powerful act of regeneration.





WELLNESS INTRO

Our WELLNESS series combines understated elegance with high functionality. The piqué weaving in two colors provides a twist to the look and makes it easy to mix with other materials and colours.

The WELLNESS towel takes up very little space when folded and dries up fast. It's therefore practical to bring to the beach or the spa. The towel is enhanced with a wrap functionality to solve the awkwardness of a towel falling down, when you trust it to stay.

Mix different colours together or mix with styles from our MILD, FINE or BIG WAFFLE series for the perfectly imperfect look.



WELLNESS BATHROBE

badekåbe
bademantel
peignoir

Are you into peaceful moments and selfcare? The Wellness Bathrobe is perfect for relaxing after a bath or starting your day with a moment of calm. Ethically made and sustainably sourced, it's wellness you can feel both inside and out.

With sleeves three-quarter length og hidden pockets.



khaki stone
no. 216



clay stone
no. 226



volcano
no. 190



evening grey
no. 111



morning grey
no. 180



Style no.	2001
Size	S/M size: 100 x 65 cm / 39,4 x 25,6" M/L size: 103 x 72 cm / 40,5 x 28,3"
Weaving	Piqué
Material	100% GOTS certified organic cotton
MOQ	2 sets



WELLNESS TOWEL

håndklæde
handtuch
serviette de bain

Developed for wellness situations, after the bath and on the beach.

This extra-large towel takes up little space when folded.

A lightweight towel with great absorbency.

Style no.	1018
Size	110 x 165 cm / 43.3 x 64.9"
Weaving	Piqué
Material	100% GOTS certified organic cotton
MOQ	4 pieces

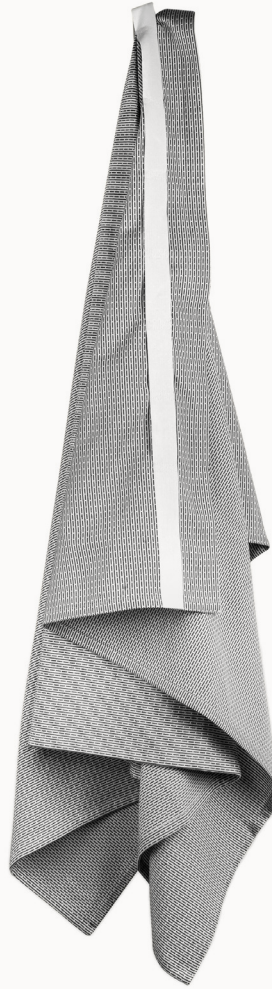

khaki stone
no. 216



clay stone
no. 226



volcano
no. 190



evening grey
no. 111



morning grey
no. 180

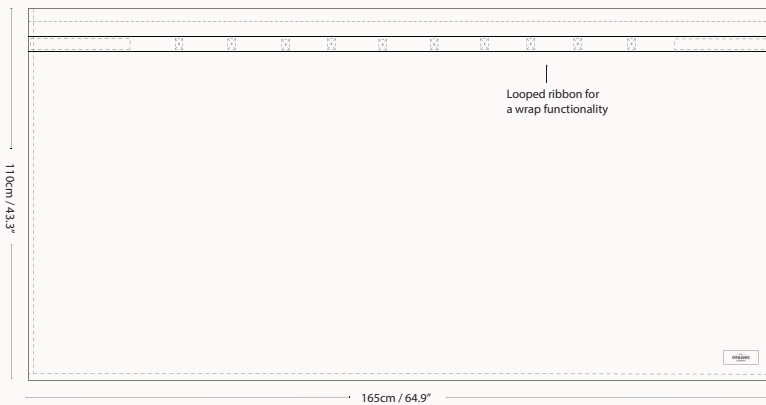



MILD INTRO

The MILD Terry Towel Collection is crafted in Portugal by a family-owned production since 1959. This collection blends tradition, quality, and contemporary design. The result is a serie of towels that not only feels luxurious but are also rooted in craftsmanship and sustainable values.

Key features of the MILD Terry Towel Collection:

- **Sustainable and superior quality:** Made from 100% GOTS-certified organic twisted 500gsm cotton for exceptional softness and durability.
- **Timeless elegance:** Available in 4 anti-fashion colours to suit the ones looking for good lint free long lasting towels.
- **Versatile sizes:** With a smaller hand and a larger bath towel the MILD Terry Towel Collection comes in usable and practical sizes. You can also get a giftset with both towel.



MILD BATH TOWEL

håndklæde
handtuch
serviette de bain

Perhaps your new favorite? Minimalistic
and super soft towel series made in
Portugal.

The towels work as you expect them to.

pale honey
no. 218



stone
no. 202



dark green
no. 400



Style no. 1195
Size 70 x 140 cm / 27.5 x 55.1"
Weaving Terry
Material 100% GOTS certified organic cotton
MOQ 4 pieces

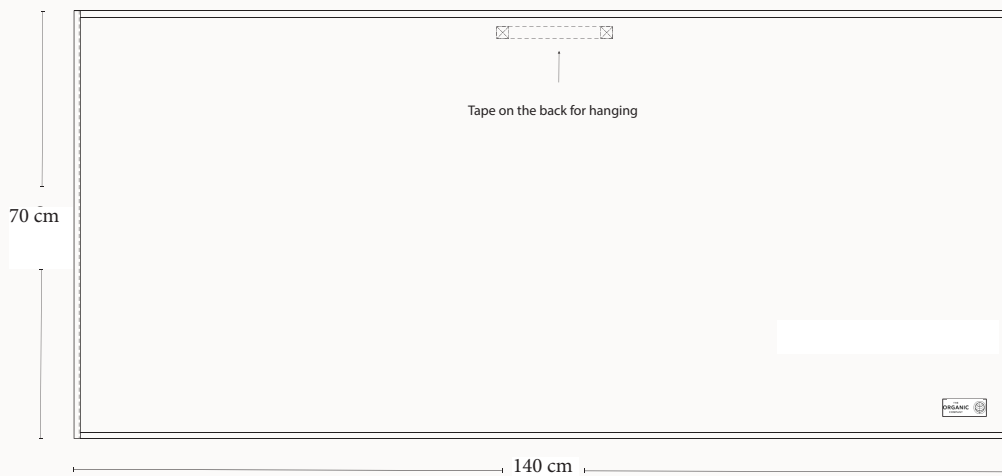

MILD HAND TOWEL

håndklæde
handtuch
serviette de bain

Perhaps your new favorite? Minimalistic and super soft towel series made in Portugal.

The towels work as you expect them to.



pale honey
no. 218



stone
no. 202



clay
no. 225



dark green
no. 400



Style no. 1196
Size 50 x 80 cm / 19.6 x 31.5"
Weaving Terry
Material 100% GOTS certified organic cotton
MOQ 4 pieces

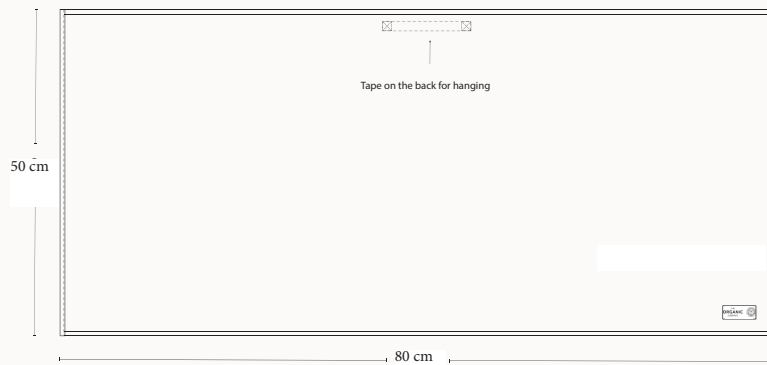



MILD GIFT SET

gavesæt
geschenkset
coffret cadeau

Our MILD gift set is perfect for that special someone.

A timeless and long lasting gift set for many occasions. Presentable, thoughtful and sustainably made in pure organic cotton.

The MILD gift set consists of one MILD bath towel and one MILD hand towel.

stone
no. 202



clay
no. 225



dark green
no. 400



Style no.	1197
Size	A gift set contains: One bath towel 70 x 140 cm / 27.5 x 55.1" One hand towel 50 x 80 cm / 19.6 x 31.5"
Weaving	Terry
Material	100% GOTS certified organic cotton
MOQ	4 pieces

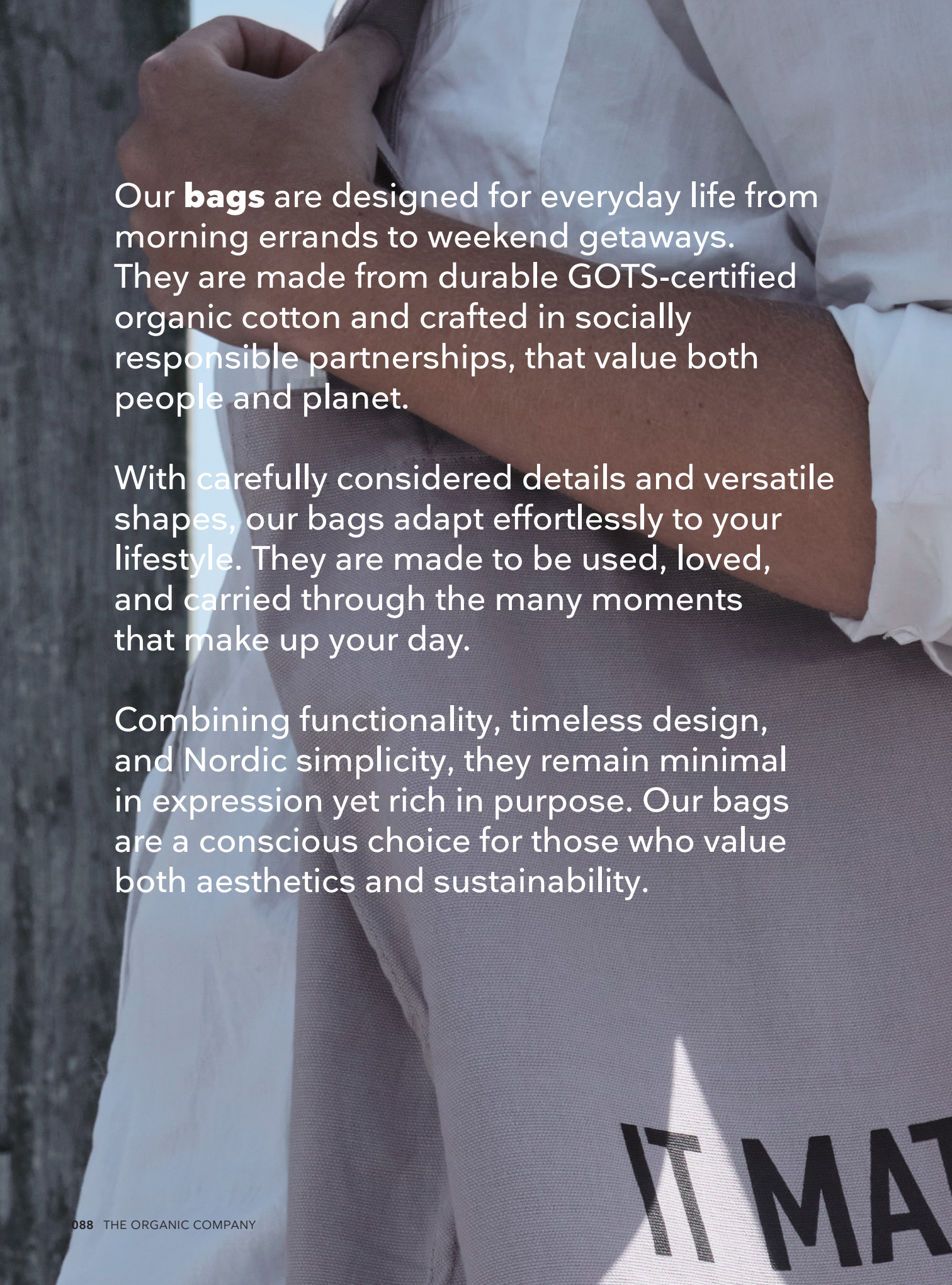

A person wearing a white long-sleeved shirt and a grey bag. The bag has the text 'IT MAT' printed on it in large, bold, black letters. The person's hands are visible, one near the top of the bag and the other near the bottom. The background is a textured, light-colored wall.

Our **bags** are designed for everyday life from morning errands to weekend getaways. They are made from durable GOTS-certified organic cotton and crafted in socially responsible partnerships, that value both people and planet.

With carefully considered details and versatile shapes, our bags adapt effortlessly to your lifestyle. They are made to be used, loved, and carried through the many moments that make up your day.

Combining functionality, timeless design, and Nordic simplicity, they remain minimal in expression yet rich in purpose. Our bags are a conscious choice for those who value both aesthetics and sustainability.



2026 / 1

LOOK BOOK

BAGS AND STORAGE

TERS

BIG LONG BAG

taske
tasche
sac

When you carry things for weekend trips, stay-overs and so on.

With our big bag, you can be sure of strength and design and of course it is made from organic cotton.

pale honey
no. 218



stone
no. 202



clay
no. 225



grey blue
no. 510



dark green
no. 400



Style no.	1009
Size	35 x 45 x 90 cm / 13.8 x 35.4 x 17.7"
Weaving	Heavy canvas
Material	100% GOTS certified organic cotton
MOQ	2 pieces

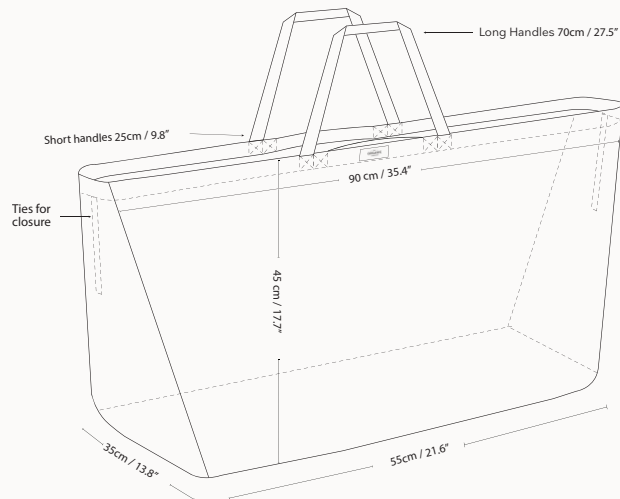

MY ORGANIC BAG



taske
tasche
sac

Ready to tote your groceries or on-the-go essentials?

Just reach inside and grab the integrated handles. Stronger and more durable than plastic.

What is your choice?



stone
no. 202



clay
no. 225



dark green
no. 400



Style no.	1016
Size	10 x 34 x 40 cm / 3.9 x 13.4 x 15.7"
Weaving	Heavy canvas
Material	100% GOTS certified organic cotton
MOQ	4 pieces

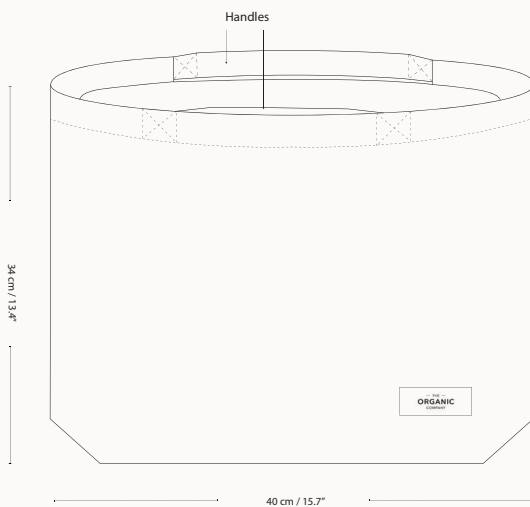

IT MATTERS BAG



taske
tasche
sac

This bag might be your favorite for many years to come. For groceries, the gym and everyday life.

If you replace disposable bags with our It Matters Bag you will help to save the planet from hundreds of disposable bags.

Style no.	1128
Size	50 x 35 x 15 cm / 19.7 x 13.8 x 5.9"
Weaving	Plain
Material	100% GOTS certified organic cotton
MOQ	8 pieces



khaki
no. 215



clay
no. 225



dusty lavender
no. 340



dark grey
no. 110



dark green
no. 400



ALL PURPOSE BAG SET

BUN
DLE
OFFER



clay
no. 225



pose
beutel
sachet

Get started with our All Purpose Bag Set of three. One small, one medium and one large.

Perfect for organizing your cloth, shoes and small items when traveling.



Style no.	SET OF 3 1115
Size	Small: 16 x 22 x 6 cm / 2.3 x 6.3 x 8.7" Medium: 24 x 30 x 8 cm / 3.1 x 9.4 x 11.8" Large: 30 x 40 x 12 cm / 4.7 x 11.8 x 15.7"
Weaving	Gauze
Material	100% GOTS certified organic cotton
MOQ	8 sets

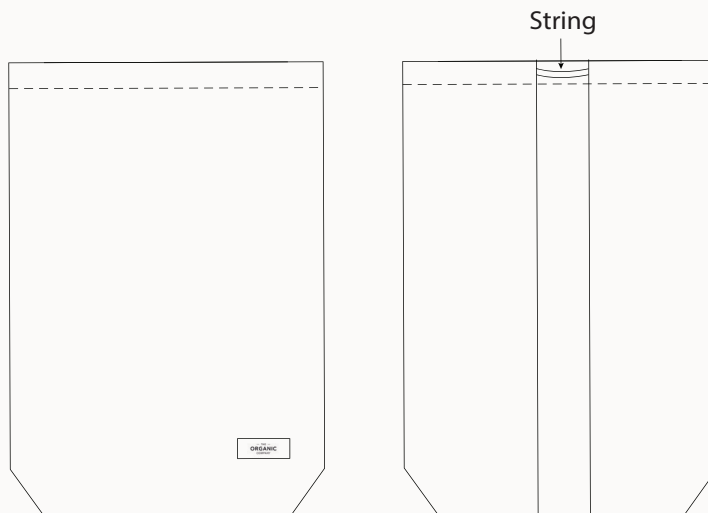

NET SHOULDER BAG

taske
tasche
sac

Our Net shoulder bag is developed for your daily life - to easily carry all your groceries and accessories on your shoulder.

Designed with a wide and solid, integrated handle, making it comfortable to carry and with strong support all around.

A spacious reusable net bag to help replace the use of disposable bags. Combine with our smaller All Purpose Bags to keep your shopping organized.



pale honey
no. 218



stone
no. 202



clay
no. 225



dark grey
no. 110



grey blue
no. 510



dark blue
no. 500



dark green
no. 400



Style no.	1153
Size	44 x 45 x 15 cm / 17 x 17.7 x 6"
Weaving	Net fabric (10's x 10's), Plain weave double
Material	100% GOTS certified organic cotton
MOQ	8 pieces

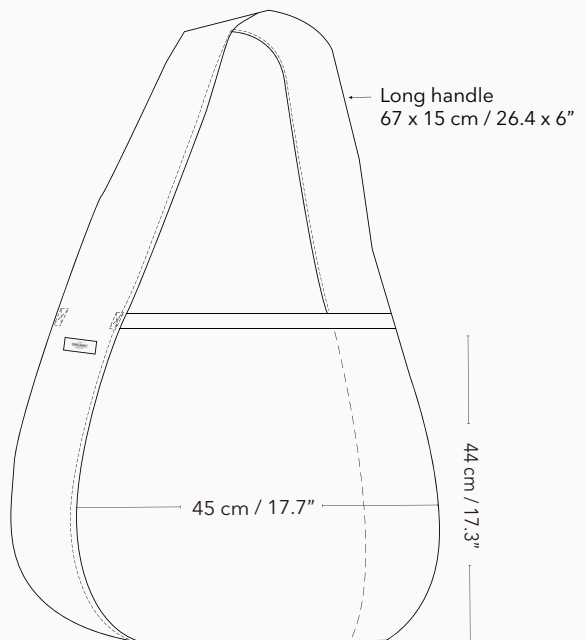

PIQUÉ TOTE BAG

pose
beutel
sachet

Our Piqué tote bag is crafted from 100% organic cotton with a textured piqué weave.

It's lightweight, durable and perfect for everyday use whether you are heading to the market, the gym and for everyday life.

This eco-friendly tote is your go-to for effortless and conscious style.

Style no.	2002
Size	50 x 35 x 15 cm / 19.7 x 13.8 x 5.9"
Weaving	Piqué
Material	100% GOTS certified organic cotton
MOQ	4 pieces



khaki stone
no. 216



clay stone
no. 226



volcano
no. 190



evening grey
no. 111



morning grey
no. 180

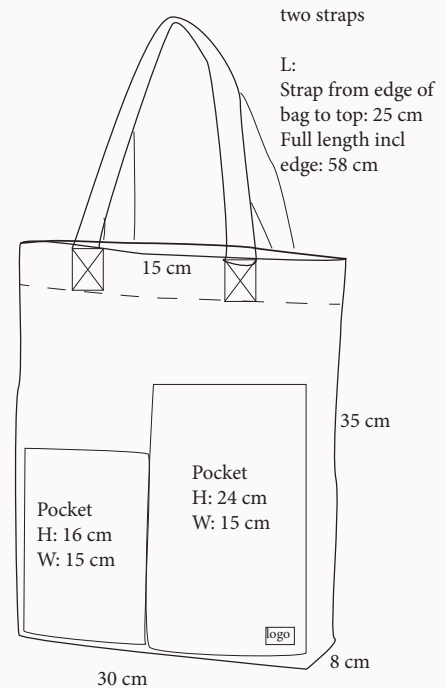



NET BAG

pose
beutel
sachet

The Net bag is a reusable bag that replaces disposable bags. It is safe as food storage or to carry your accessories around.



stone
no. 202



clay
no. 225



dusty lavender
no. 340



dark green
no. 400



SMALL

Style no. 1107
Size 22 x 16 x 6 cm / 2.32 x 6.3 x 8.6"
Weaving Net fabric (10's x 10's)
Material 100% GOTS certified organic cotton
MOQ 8 pieces

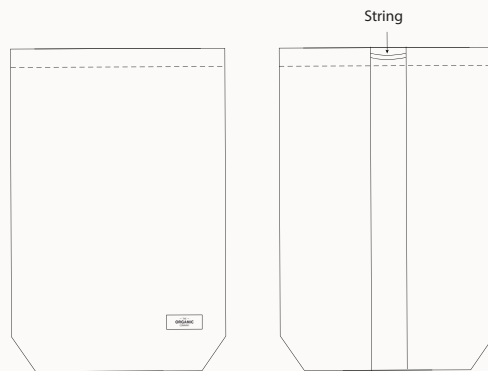

MEDIUM

Style no. 1108
Size 24 x 30 x 8 cm / 3.1 x 11.8 x 9.8"
Weaving Net fabric (10's x 10's)
Material 100% GOTS certified organic cotton
MOQ 8 pieces

LARGE

Style no. 1109
Size 30 x 40 x 12 cm / 4.7 x 11.8 x 15.7"
Weaving Net fabric (10's x 10's)
Material 100% GOTS certified organic cotton
MOQ 8 pieces

BIG SHOULDER BAG

taske
tasche
sac

Our Japanese inspired Big Shoulder Bag is designed for both everyday life and joyful weekends, as a tribute to Japanese design traditions.

Spacious and big enough to hold your favorite things on the go.

Developed with an adjustable, strong carrying strap and adjustable side straps to resize the bag for all purposes.

Includes a zippered external pocket for fast access to your smaller items and keys, and an internal pocket and strap for holding and organizing content inside the bag.

Made with beautiful and practical details in a durable, heavy canvas weave of organic cotton to be enjoyed for a long time.

Style no.	1137
Size	40 x 44 x 17 cm / 15.7 x 17 x 6.7"
Weaving	Heavy canvas
Material	100% GOTS certified organic cotton
MOQ	2 pieces

murakami - clay
no. 227



hayao - grey blue
no. 512



rei - dark blue
no. 502

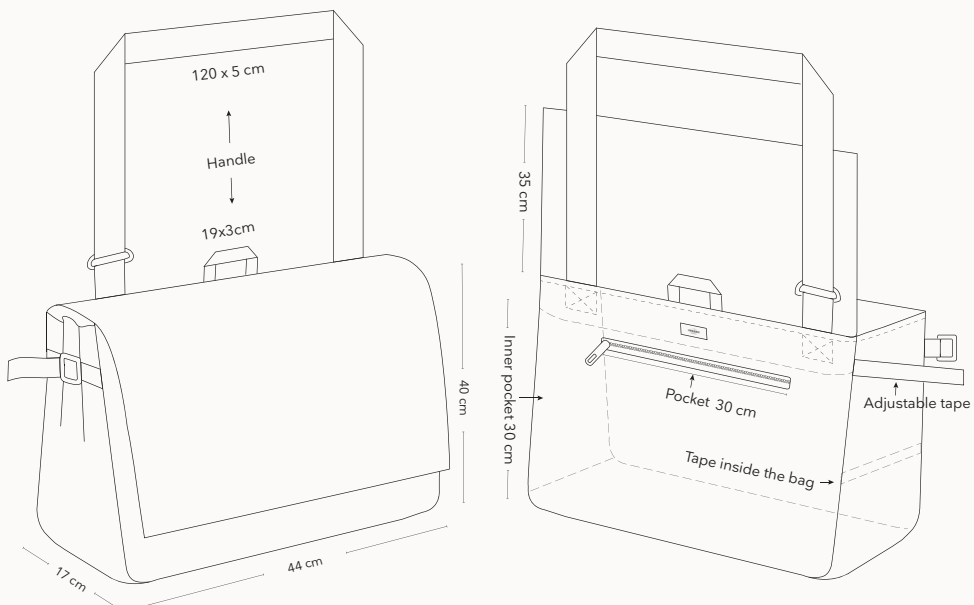

WASHING BAG SET

vaskepose
wäschesack
sac à linge

natural white
no. 200



clay
no. 225



One set contains 3 different sizes.
one small, one medium and one large bag.

Our washing bag is an alternative to:

- 1) washing bags made of plastic
- 2) not using a protective bag

Helps to make your most delicate clothes last longer.

What is your choice?



SET	1090
Style no.	1090
Size	S: 17 x 25 cm / 6.7 x 9.8" M: 25 x 34 cm / 9.8 x 13.4" L: 34 x 50 cm / 13.4 x 19.7"
Weaving	Gauze
Material	100% GOTS certified organic cotton
MOQ	8 sets

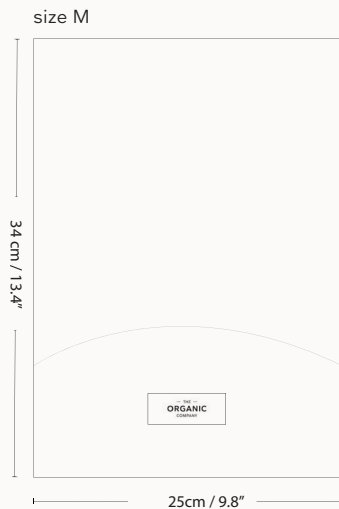

FRONT

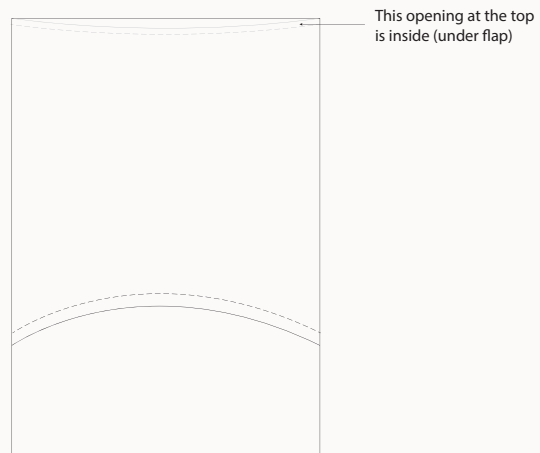

BACK

A person is sitting on a concrete ledge, looking out over a rocky coastline. The ocean is visible in the background, and there are other people sitting on the ledge in the distance. The scene is bright and sunny.

Our **relax and meditation collection** has all the essentials: two supportive meditation mattresses, a soft blanket, and a comfortable pillow. Each item is made to help you create a peaceful space for rest and stillness.

Whether you're meditating, stretching, or simply taking a quiet moment for yourself, this minimalist set supports not only your well-being but also the well-being of the planet.

Our relax and meditation collection is made from natural and organic materials.

2026 / 1



LOOK BOOK

RELAX AND MEDITATION

MEDITATION MATTRESS - TO GO

madras
matte
matelas

Meditation is for many the key to inner peace.

Our mattress is developed to make it easier for you to reach this state of mind; it's soft, comfortable and made from pure organic cotton, also on the inside.

Easy to carry with the accompanying belt. Washable cover and easy to bring along, to go.



dark blue
no. 500



dark grey
no. 110



Style no.	1064
Size	70 x 200 cm / 1.2 x 27.5 x 78.7"
Weaving	Herringbone, organic cotton wadding
Material	100% GOTS certified organic cotton
MOQ	2 pieces



MEDITATION MATTRESS

clay
no. 225



madras
matte
matelas

Meditation is for many the key to inner peace.

Our mattress is developed to make it easier for you to reach this state of mind; it's soft, comfortable and made from pure organic cotton, also on the inside.

Washable cover.



Style no.	1126
Size	70 x 200 cm / 1.2 x 27.5 x 78.7"
Weaving	Canvas, organic cotton wadding
Material	100% GOTS certified organic cotton
MOQ	2 pieces

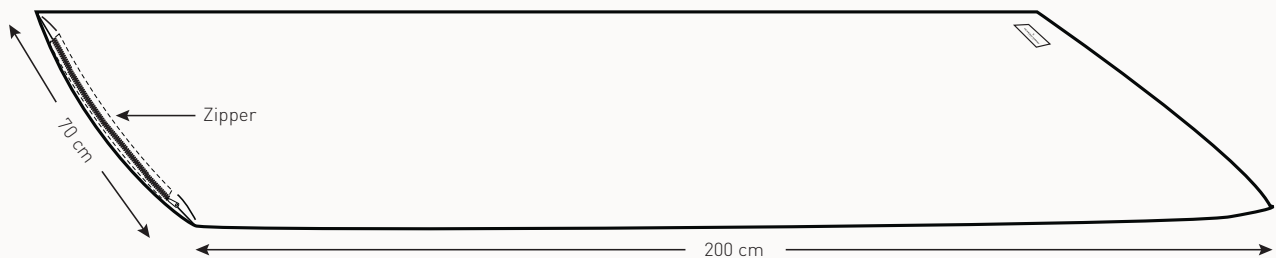

A photograph of a person sitting in a field of tall, golden-brown grass. The person is wearing a pink blanket or jacket, which is draped over their lap and legs. The background is a dense line of green trees under a blue sky with scattered white clouds. The lighting is bright, suggesting a sunny day.

Reconnect with nature

Spend more time outside and let nature set the pace. Regeneration starts when we slow down enough to notice the small things: the changing light, the feel of air on our skin or the ground under our feet. When we reconnect, we remember that we too are a part of nature.



6-LAYER SOFT BLANKET

tæppe
decke
couverture

Delicate throw for the many times you are needing that extra cosy layer. At home or when outdoors, taking care of yourself.

Pure and soft on your skin with no less than six organic cotton lightweight layers.

Keeping you warm for your meditative and relaxing moment.



stone
no. 202



dusty lavender
no. 340



dark grey
no. 110



Style no.	1063
Size	140 x 200 cm / 55.1 x 78.7"
Weaving	Gauze
Material	100% GOTS certified organic cotton
MOQ	2 pieces

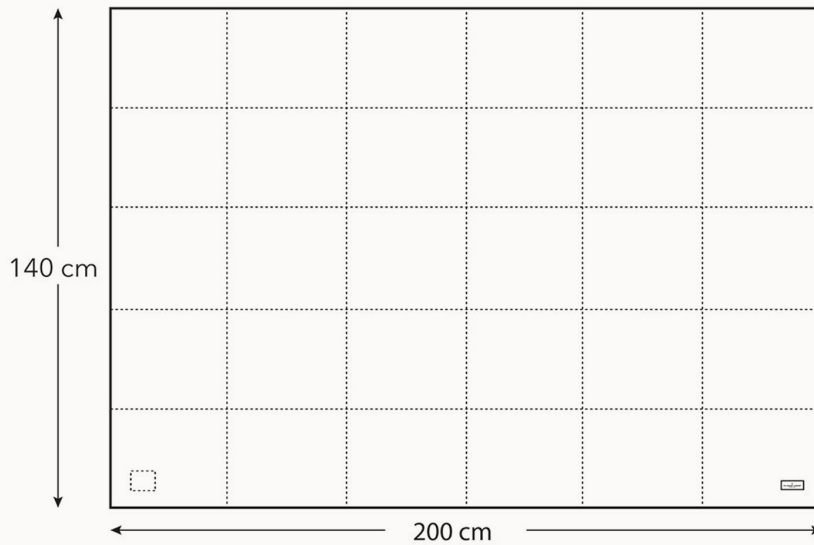

RELAX AND MEDITATION CUSHION

pude
kissen
coussin

For a better posture when meditating and doing some seated yoga poses. Filled with pure organic cotton to support an organic lifestyle in balance.

Washable cover.



stone
no. 202



dusty lavender
no. 340



clay
no. 225



dark grey
no. 110



dark blue
no. 500



Style no.	1167
Size	30 x 20 x 5 cm / 11.8 x 7.9 x 2.0"
Weaving	Heavy canvas
Material	100% GOTS certified organic cotton
MOQ	4 pieces

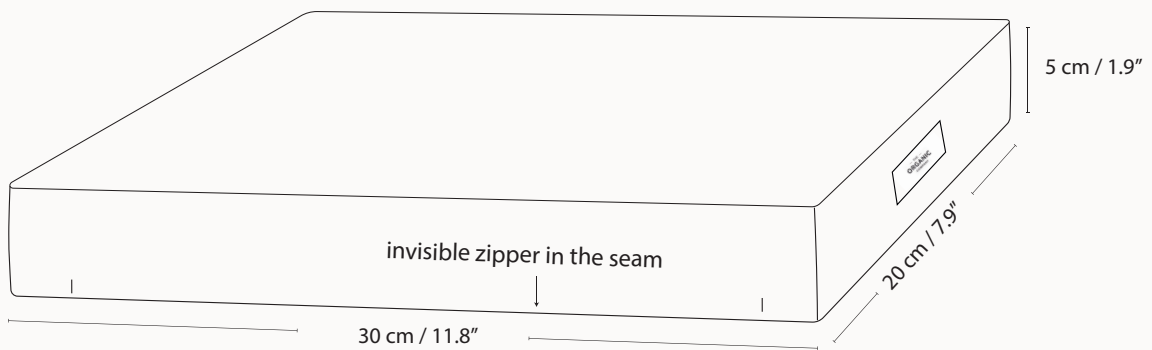



To help you present The Organic Company in the best possible way, we provide **POS materials** that support in-store styling and organization. Our materials are designed to support your visual merchandising from organizing smaller items to creating a clear and calm brand presence that reflects what The Organic Company is all about.

We encourage you to use these materials to tell the story of simplicity, functionality, and sustainable living – the core of The Organic Company.

If you need help or have questions about display setup, please don't hesitate to reach out. We are here to support you.





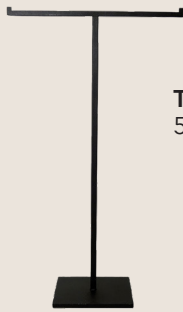

T-TABLE DISPLAY made in iron
55 x 43-81 cm / 21.6 x 16.9-31.9"



LOGO BLOCK made with FCS
certified wood
24 x 18 x 3 cm / 9.4 x 7.1 x 1.2"



TRAY BOX SET made from a mix of recycled
cardboard and cotton

S: 23.5 x 11.5 x 6 cm / 9.3 x 4.5 x 2.4"
M: 26.5 x 22.5 x 6 cm / 10.4 x 8.7 x 2.4"
L: 33.5 x 29.5 x 6 cm / 12.8 x 11.6 x 2.4"



A5 CLIPBOARD made with
FCS certified wood
17 x 24 x 5cm / 6.7 x 9.4 x 1.9"

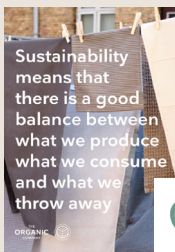

A5 POST CARDS with pictures
and statements

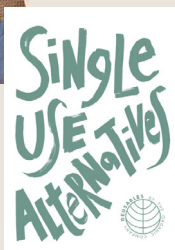

DISPLAY KITCHEN CLOTH with 48
kitchen cloths on display



— THE —
ORGANIC
COMPANY

ORGANIC
EVERYDAY NAPKIN

ORGANIC
FOOD BAG SET

ORGANIC
DINNER NAPKIN

ORGANIC
DINNER NAPKIN

REUSABLES BY THE
COMPANY
ALTERNATIVES
to single use items

ORGANIC
KITCHEN TOWEL

CALM HAND TOWEL
CALM HAND TOWEL
CALM HAND TOWEL

KITCHEN TOWEL
KITCHEN TOWEL
KITCHEN TOWEL

CREATIVE AND GARDEN APRON
CREATIVE AND GARDEN APRON

BEST IN TEST
REUSABLES BY THE COMPANY
ORGANIC AND LONG-LASTING

ORGANIC
SH CLOTH
KITCHEN AND WASH CLOTH
KITCHEN & ...

ORGANIC

B CORPORATION CERTIFICATION



We are proud to be a certified B Corporation. After a long and detailed process we became certified in 2022.

The B stands for 'Benefit for all'. The B Corp Certification is holistic, not exclusively focused on a single social or environmental issue. And the process to achieve and maintain the certification is profound.

In combination with our GOTS certification it's a complete and holistic set of certifications that show our high level of responsibility throughout the value chain as well as our focus on organic production, social responsibility and transparency.



GOTS - GLOBAL ORGANIC TEXTILE STANDARD

When producing our products it is crucial for us to make sure that we produce at nobody's expense. This being both people and the environment - nobody should suffer.

That is why we carefully choose our suppliers and only work with GOTS certified suppliers. The standard not only complies with environmental criterias it also secures ethical treatment of the workers from the farmer to the sewing house.

"GOTS is the world's leading textile processing standard for organic fibres, including social and ecological criteria, backed up by independent third-party certification of the entire textile supply chain."

GOTS positions itself as a voluntary standard, which does not aim at maximising profits, but at enhancing people's lives along supply chains and the environmental state of our planet." - Quote GOTS

THE ORGANIC COMPANY

THE ORGANIC COMPANY APS

Østersøvej 28A, Stack 0, 1. sal tv.
2150 Nordhavn
Denmark

+45 42 15 11 11
info@theorganiccompany.dk

www.theorganiccompany.dk
www.theorganiccompanydk.com

 The.Organic.Company

 @theorganiccompany

POLAND

3f Studios
info@3fstudio.pl
+22 651 56 44
+693 121 316
www.3fstudio.pl
@3fstudio_konwiktorska

ITALY

Casagin
Contact person: Daniela
info@casagin.com

SWITZERLAND

Maison Truffe
Laubisrütistrasse 52
CH-8712 Stäfa
+41 44 928 25 25
Email: kundendienst@maisontruffe.ch



2026 / 1

LOOK BOOK

FIND US

JAPAN

Tamurakoma & CO., LTD. (Sec.315)
3-3-9, Azuchimachi,
Chuo-Ku, Osaka,
541-0052, Japan

CANADA

Warner McDaniel Agency
warnermcdaniel@gmail.com
+1 604-288-0050
www.warnermcdanielagency.com
@warnermcdanielagency

USA

Sweet Pea
amy@sweetpeagift.com
+1 360-561-1388
www.sweetpeagift.com

OTHER MARKETS

The Organic Company
info@theorganiccompany.dk
+45 42 15 1111
www.theorganiccompanydk.com

PHOTO CREDITS

Alex Buck Maurer + Sisse Langfeldt + Line Thit Klein + Anne Mie Drewes + Storm Ravn + Høgh&Møller
The Organic Company + Julie Bjørnhoff + Helle Moos

Copyright © 2026.
All rights reserved.

*To download the product images
used in the catalogue go to:*
<https://photograb.kontainer.com/folder/1149331>

THE ORGANIC COMPANY

info@theorganiccompany.dk
+45 42151111

www.theorganiccompany.dk
www.theorganiccompanydk.com

 @theorganiccompany



SUPPORT
BRANDS, FARMERS,
AND COMMUNITIES
WHO RESTORE
RATHER THAN EXPLOIT.
WHEN WE SPEND
WITH INTENTION,
WE VOTE FOR
THE WORLD
WE WANT